



FEATURES

- Lowest-cost LED meters
- Subminiature size:
1.38" x 0.88" x 0.48" (35mm x 22mm x 12mm)
- Large (0.37"/9.4mm) LED display
- Choice of 6 LED colors
- High-intensity or low-power (7mA) red LEDs optional
- Epoxy-encapsulated, 12-pin DIP package with built-in color filter and bezel
- 4 differential input voltage ranges
- Factory calibrated, ±1 count accuracy
- Single +5V power supply
- User-selectable decimal point placement
- DISPLAY ENABLE function for "power-down" mode
- DISPLAY TEST and HOLD (optional) functions
- 0 to +60°C temperature range

DMS-20PC Series, 3½ Digit, LED Display, Digital Panel Voltmeters combine a precision A/D converter; a factory-trimmed, highly stable, voltage reference; and a large (0.37"/9.4mm), easy-to-read LED display in a single package that is only slightly larger than the display itself. Displays are offered in either red, orange, amber, yellow, green or blue colors. High-intensity and low-power (35mW total) red LEDs are also optional.

These low-cost meters are fully self-contained and fully functional. Their subminiature (1.38" x 0.88" x 0.48"), epoxy-encapsulated cases incorporate built-in color filters and bezels; are moisture and vibration proof; and function well in the harshest environments. Their 12-pin, dual-in-line configuration offers component-like, plug-in convenience and maximum versatility. Operating temperature range is 0 to +60°C.

The meters come with one of four, differential, input voltage ranges: ±200mV, ±2V, ±20V or ±200V. Input impedance is a minimum 800kΩ. CMRR is typically 86dB (dc to 60Hz), and CMV is ±2V. Input overvoltage protection (on the non-inverting input) is ±250V. Devices are fully calibrated at the factory to an accuracy of ±1 count (±0.05% of full scale range) and never require calibration or adjustment.

A DISPLAY ENABLE function permits the display to be disabled for "power-down" operation. All models have a DISPLAY TEST function. Standard red LED models offer an optional DISPLAY HOLD function.

Small size, low cost and adjustment-free reliability make the DMS-20PC Series the best choice for all your 3½ digit, LED, DPM applications.

SIMPLIFIED SCHEMATIC DIAGRAM

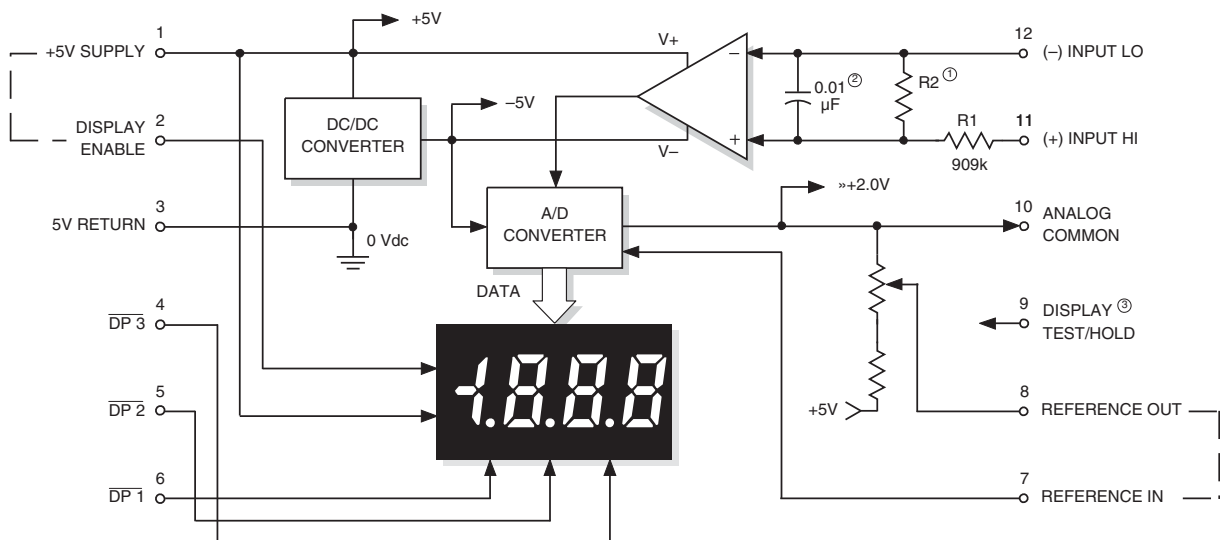

25
For full details go to
www.murata-ps.com/rohs

① R2 is not used on ±200mV (-0) models or ±2V (-1) models.
R2 = 100k on ±20V (-2) models and 9.1k on ±200V (-3) models.

② Only used on ±200mV (-0) and ±2V (-1) models.

③ Pin 9 is DISPLAY TEST on all but eight models. On those models (-H option), it is DISPLAY HOLD.

Figure 1. DMS-20PC Series simplified schematic

Performance/Functional Specifications

Typical at T_A = +25°C and supply voltage = +5V using the single-ended input circuit, unless otherwise noted.

| Analog Inputs | Min. | Typ. | Max. | Units |
|----------------------------------|------|------|------|-------|
| Full Scale Input Range: | | | | |
| DMS-20PC-0 | – | ±200 | – | mV |
| DMS-20PC-1 | – | ±2 | – | Volts |
| DMS-20PC-2 | – | ±20 | – | Volts |
| DMS-20PC-3 | – | ±200 | – | Volts |
| Input Impedence: | | | | |
| DMS-20PC-0, -1 | – | 1000 | – | MΩ |
| DMS-20PC-2, -3 | – | 1 | – | MΩ |
| Overvoltage Protection ① | | | | |
| | – | – | ±250 | Volts |
| Common Mode Voltage Range | | | | |
| | – | – | ±2 | Volts |
| CMRR (dc to 60Hz) | | | | |
| | – | 86 | – | dB |

| Performance | | | | |
|--|------------------------|-------|-------|---------|
| Sampling Rate | 2.5 reading per second | | | |
| Accuracy (3 minute warm-up): | | | | |
| DMS-20PC-0 (V _{in} = +0.19V) | – | ±1 | ±3 | Counts |
| DMS-20PC-1 (V _{in} = +1.9V) | – | ±1 | ±3 | Counts |
| DMS-20PC-2 (V _{in} = +19V) | – | ±2 | ±3 | Counts |
| DMS-20PC-3 (V _{in} = +190V) | – | ±2 | ±3 | Counts |
| Zero Reading (V_{in} = 0 Volts) | “–001” | “000” | “001” | |
| Temperature Drift (0 = +60°C) | – | ±0.2 | ±0.4 | Cnts/°C |

| Power Supply Requirements | | | | |
|------------------------------|-------|-------|-------|-------|
| Supply Voltage | +4.75 | +5.00 | +5.25 | Volts |
| Supply Current: | | | | |
| DMS-20PC-X-RL | – | +7 | +12 | mA |
| DMS-20PC-X-BL & -PGL | – | +12 | +17 | mA |
| DMS-20PC-X-RS, -RH | – | +60 | +90 | mA |
| DMS-20PC-X-RS-H | – | +60 | +90 | mA |
| DMS-20PC-X-BS | – | +75 | +100 | mA |
| DMS-20PC-X-GS-H | – | +90 | +120 | mA |
| DMS-20PC-X-AS, -GS, -OS, -YS | – | +90 | +120 | mA |

| Display | | | | |
|----------------------------------|---|---|-----|----|
| Display Type and Size | 3½ digit, 0.37"/9.4mm high LED | | | |
| Polarity Indication | Autopolarity (“–” for negative V _{in}) | | | |
| Overrange Indication | “–1___” for negative inputs “1___” for positive inputs | | | |
| Physical/Environmental | | | | |
| Operating Temperature | 0 | – | +60 | °C |
| Storage Temperature | –20 | – | +75 | °C |
| Humidity (non-condensing) | 0 | – | 95 | % |
| Case Material | Polycarbonate | | | |
| Weight | 0.4 ounces (11 grams) | | | |

① Applies for transient or continuous overvoltages applied to (+) INPUT HI (pin 11) with (–) INPUT LO (pin 12) properly connected. Pin 12 is not overvoltage protected (see Figure 1). Voltages applied to pin 12 should not exceed the supply voltage.

② See Technical Notes.

③ The DISPLAY HOLD function is optional on standard red and green LED models only.

Ordering Information

DMS-20PC - 1 - RS - C

Input Range:

0 = ±200mV
1 = ±2V
2 = ±20V
3 = ±200V

Add -C for RoHS

Leave blank for standard models.
Add -H for DISPLAY HOLD option (available on standard red and green LED models only).

LED Color:

AS = Standard Amber
BS = Standard Blue
GS = Standard Green
OS = Standard Orange

RS = Standard Red
YS = Standard Yellow
RH = High-Intensity Red
RL = Low-Power Red
BL = Low-Power Blue
PGL = Low-Power Green

Accessories:

DMS-20-CP Panel cutout punch
DMS-BZL3-C DMS-20 bezel assembly
DMS-BZL4-C DMS-20 bezel assembly with sealing gasket
DMS-EB2-C Application/evaluation board with standard MOLEX connector, decimal point solder pads and attenuation resistor pads.

A panel-mount retaining clip is supplied with each model.

TECHNICAL NOTES

- REFERENCE OUTPUT (Pin 8) and INPUT (Pin 7):** Pin 8 is a precision reference actively trimmed at the factory. In normal operation, pin 8 must be tied to pin 7 to achieve all listed accuracy and drift specifications.
- ANALOG COMMON (Pin 10):** This pin is connected to an internal, low-noise, "relative" ground. It is used in certain differential and "floating" measurements as described in the Applications section of this data sheet and Ap Note 3 of the DATEL Panel Meter Catalog. Pin 10 should not be connected to pin 3 (5V RETURN) or to your system's analog ground.
- Decimal Point Placement:** The location of the decimal point is user-selectable, and the decimal point control pins (DP1-DP3) are active low functions. Select the appropriate decimal point by tying the appropriate pin (pin 4, 5 or 6) to pin 3 (5V RETURN). Unused decimal point location pins should be left open.

Hard wiring is preferable, however, you can use logic gates to exercise dynamic control over the location of the decimal point if the following drive conditions are met:

| Model | Applied "0" Voltage | Load Current* |
|---------------|---------------------|---------------|
| DMS-20PC-X-XL | +0.05V max. | 0.7mA max. |
| All Others | +0.4V max. | 6mA max. |

* The driving gates must be able to sink this much current

4. DISPLAY TEST/HOLD (Pin 9) Function: Pin 9 is a dual-function pin. On all standard models (without "-H" suffix), tying pin 9 to pin 1 (+5V SUPPLY) activates the meter's DISPLAY TEST feature. All display segments, except the decimal points, will be illuminated. The display will show "1888" ("–1888" if a negative input signal is present). Do not leave the meter in the test mode for more than 10 seconds as this will cause the meter's operating temperature to rise and possibly affect its performance. Pin 9 must be left open when the test function is not being used.

On models with the "-H" suffix (DMS-20PC-1-RS-H for example), pin 9 serves as a DISPLAY HOLD control pin. Tying pin 9 to +5V SUPPLY (pin 1) on these models will hold or "freeze" the current display reading indefinitely. Pin 9 must also be left open when the hold function is not being used. After disabling DISPLAY HOLD, allow the meter a full 10 seconds to resume normal calibrated operation before holding a new reading.

The DISPLAY TEST or DISPLAY HOLD pin should normally be connected, via a selector switch, to pin 1 (+5V SUPPLY). If automatic, logic-controlled operation is desired, only PNP or MOSFET transistors should be used. The base or gate of these transistors should be driven sufficiently hard to bring pin 9 within 0.05V of +5V SUPPLY.

5. DISPLAY ENABLE (Pin 2) Function: On all models, tying pin 2 to pin 1 (+5V SUPPLY) applies full power to the LED display. This is the normal mode of operating the meter. Leaving DISPLAY ENABLE open (no connection), only turns off the LED display. The meter's analog-to-digital converter continues to sample the input signal. Total current consumption with the display off is approximately 400µA (0.4mA). This is a very useful feature if the meter is used in battery-powered equipment.

With the exception of the low-power red LED models (DMS-20PC-X-RL), a regulated voltage lower than +5V SUPPLY can be used to dim the display intensity. Display intensity control is best performed with the high brightness, red LED, DMS-20PC-X-RH model. All low-power red LED models must have DISPLAY ENABLE tied directly to pin 1 (+5V SUPPLY). Voltages applied to DISPLAY ENABLE must never be greater than +5V SUPPLY.

6. Gain Adjust: There is a gain-adjust potentiometer on the back of each meter. It has approximately ±50 counts (±2.5%) range of adjustment. Since these devices essentially have no zero/offset errors, a gain adjustment is effectively an overall accuracy adjustment. Though they may be performed at any point (except zero), accuracy adjustments are most effective when performed with higher level input signals. The circuit shown in Figure 10 provides ±10% range of adjustment.

7. Soldering Methods: All models in the DMS-20PC Series easily withstand most common wave soldering operations. We recommend, however, that you evaluate the effects your particular soldering techniques may have on the meter's plastic case and high-precision electrical performance. We recommend the use of no-clean solders.

8. Suggested Mating Connectors:

| | |
|---------------------|----------------------------------|
| Panel mounted: | |
| Connector housing | DATEL P/N 4320-01069-0 |
| Terminal type | DATEL P/N 4400-01032-0 |
| Crimping tool | DATEL P/N 39-2099000 |
| Wire size | 22 to 26 AWG |
| Insulation diameter | 0.062" (1.57mm) maximum |
| Stripping length | 0.100 to 0.125" (2.54 to 3.17mm) |

Board mounted:
Socket DATEL P/N 4320-01074-0

APPLICATIONS

DMS-20PC meters are highly versatile devices that can be used in hundreds of applications. The application circuits chosen for this section are ones that have historically received many inquiries.

The schematic in Figure 1 shows that the meter's high-impedance input consists of an op amp powered from a ±5Vdc power supply (the –5V is internally generated). One can easily see why input signals applied to (–) INPUT LO and (+) INPUT HI have to be kept within the power supply rails of ±5V. Also note that only pin 11 has a current-limiting 909kΩ series resistor. High input voltages that have a common ground with pin 3 (5V RETURN) should only be applied to pin 11 ((+) INPUT HI) and never to pin 12. In these high-voltage cases, pin 12 should always be tied to pin 3 (5V RETURN).

The schematic also shows that pin 3 is the meter's zero-volt reference point — regardless of the type of power or signal source used. This is an important point to keep in mind when a digital or analog multimeter is used to make system measurements. The multimeter's negative lead (usually the black one) must be connected to pin 3 (5V RETURN).

1. Single-Ended Input Configurations: True single-ended measurements can be made with any DMS-20PC meter. The circuit of Figure 2 avoids problems normally associated with ground-loop currents. Separate ground runs should be used for 5V RETURN (pin 3) and (–) INPUT LO (pin 12).

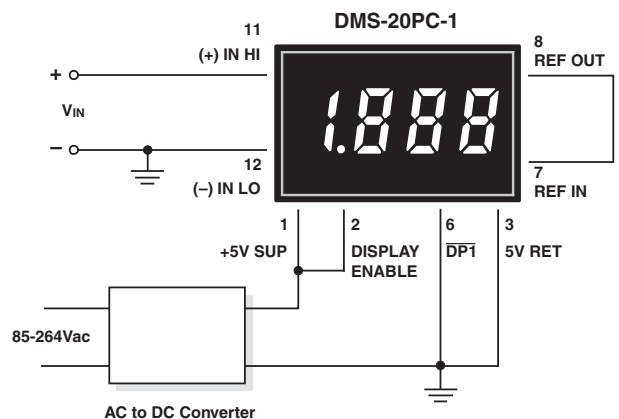

Figure 2. Single-Ended Input Configuration

APPLICATIONS

2. Differential Input Configurations: Differential measurements can be made with all DMS-20PC meters. Figure 3, though not a practical real-world application, uses a voltage divider to demonstrate the concept of a differential input signal. Be careful not to exceed the ±2V common mode voltage limitation for 5V-powered meters.

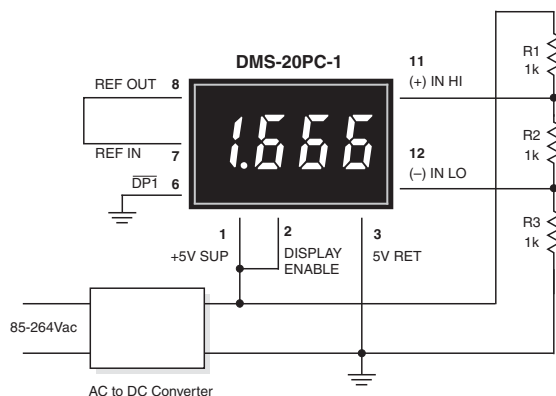

Figure 3. Differential Input Configuration

3. Engineering Scaling: For measuring voltages greater than the full scale input range of a given meter, the input signal must be attenuated. A simple voltage divider (similar to that shown in Figure 4) will scale the input to within the range of the selected meter. R1 and R2 should be precision, ±1%, metal-film resistors with absolute TCR's less than 50ppm/°C. See Ap Note 4 for more information on engineering scaling.

$$50k\Omega < R1 + R2 < 10M\Omega$$

$$\frac{R2}{R1 + R2} \times V_{IN} = \text{Reading}$$

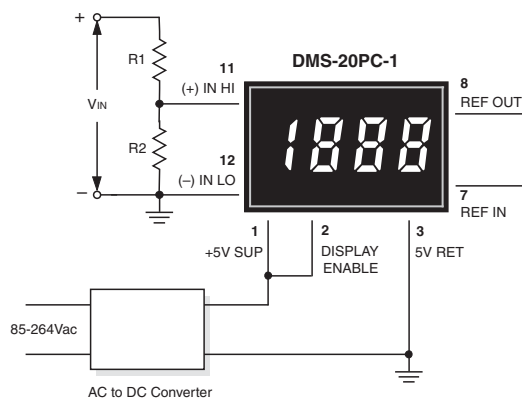

Figure 4. Input Attenuation Circuit

4. Floating Signal Source Measurements: Floating signals can be measured using the circuits shown in Figures 5 and 6. Connecting pin 10 (ANALOG COMMON) or pin 3 (5V RETURN) to (-) INPUT LO (pin 12) provides the reference point for the meter's input.

A "floating" input is a signal that has no galvanic connection to the meter's power supply. In the figures below, the 1.5V battery illustrates a true floating input.

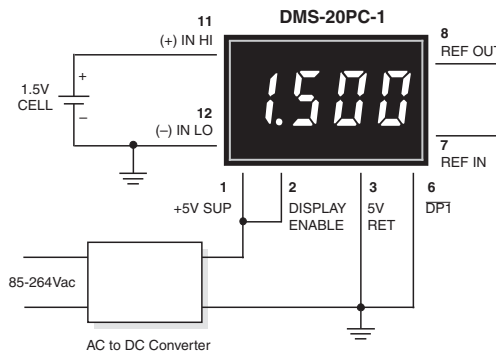

Figure 5. Floating Input Measurements

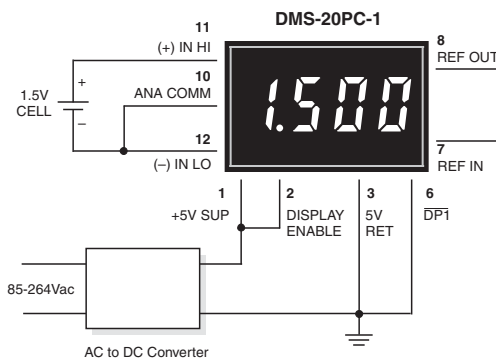

Figure 6. Floating Input Measurements (Alternate Configuration)

5. Process Control (4-to-20mA) Measurements: In many common process-control applications, a 4-to-20mA current loop is used to transmit information. Because DMS-20PC meters have such high input impedance, a simple shunt resistor across the meter's input can be used to convert the loop current to a voltage. See Figure 7. The value of the shunt resistor is a function of the scaling requirements of the particular application and can be calculated using the following equation:

$$R_{\text{Shunt}} = R1 = V_{\text{Fsr}} / I_{\text{Fsr}}$$

Where: V_{Fsr} = Full scale reading (in Volts)

I_{Fsr} = Relative full scale current (in Amps)

APPLICATIONS

Example: For a meter with a 2V full scale input (1.999 full scale reading) and a desired display reading of "1000" (with an input of 20mA), $V_{Fsr} = 1.000$ Volts

$$R_{Shunt} = 1.000V / (0.020 - 0.004)A$$

$$R_{Shunt} = 1.000V / 0.016A = 62.5 \text{ Ohms}$$

To calibrate the circuit of Figure 7, perform the following:

1. With 4mA applied, adjust the 50kΩ potentiometer (R2) to display a reading of "000" (assuming that is the desired reading).
2. With 20mA applied, adjust the gain-adjust potentiometer on the back of the meter to display a reading of "1000".
For different full scale readings, alter the value of R_{Shunt} accordingly.

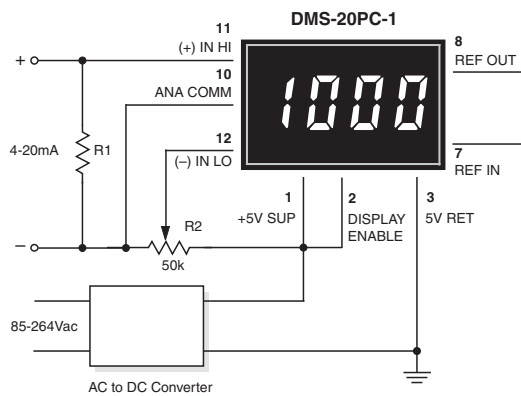

Figure 7. 4-to-20mA Current Loop Operation

6. Power Supply Monitoring: One of the most common digital panel meter applications involves monitoring the output voltage of the system power supply — often this supply also powers the meter itself. The low-power, red LED DMS-20PC-2-RL can be configured to allow power supply monitoring over the range of 4.5-18Vdc. The circuit in Figure 8 uses a low-drop-out, three-terminal regulator (LM-2931Z-5, available from National Semiconductor) to provide regulated 5V-power to the meter.

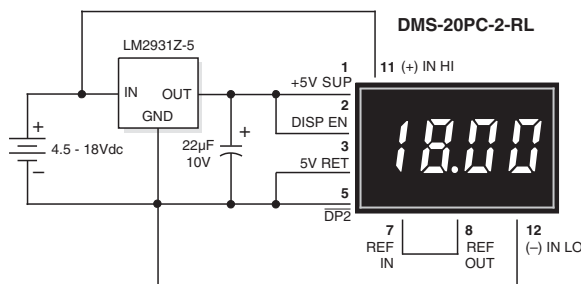

Figure 8. 4.5-18V Power Supply Monitor

The LM-2931 was chosen because it has the following on-chip protection features: reverse polarity, short circuit and thermal runaway. When using other, higher-power, DMS-20PC models with three-terminal regulators, be sure to consult the regulator manufacturer's data sheet to ensure the regulator is being utilized safely and correctly.

7. Digital Ammeter: Digital ammeters are finding ever-increasing usage because analog-style ammeters (moving-vane types) now cost roughly the same as their digital counterparts. Additionally, analog ammeters are not nearly as rugged as modern digital panel voltmeters. Figure 9 illustrates a typical ammeter application. The circuit uses a ±200mV input meter — the preferred range for most ammeters — to measure the voltage developed across a 0.1Ω current shunt. The circuit shown represents a basic ammeter connection diagram. A detailed application note describing digital dc ammeters is included in DATEL's new Digital Panel Meter Databook.

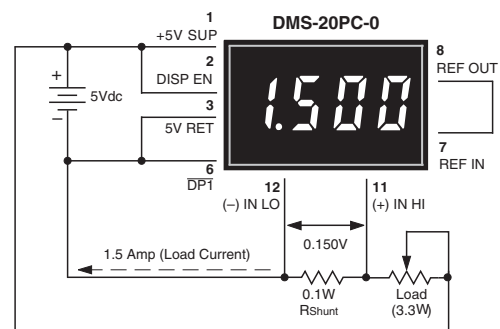

Figure 9. Basic DC Ammeter Circuit

8. External Gain Adjustment: Connect REFERENCE OUT (pin 8) to REFERENCE IN (pin 7) for normal, factory calibrated, operation. Use the circuit shown in Figure 10 for applications needing external gain adjustment. Calibration is performed with a precise, near-full-scale, input voltage.

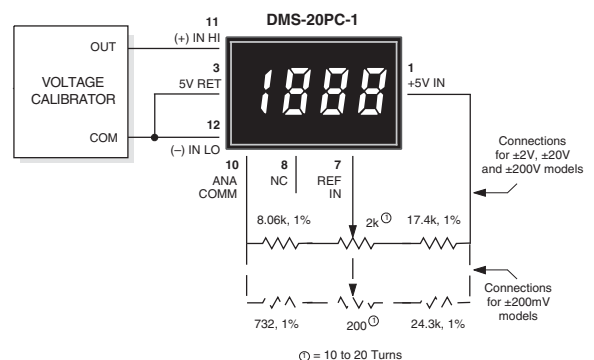
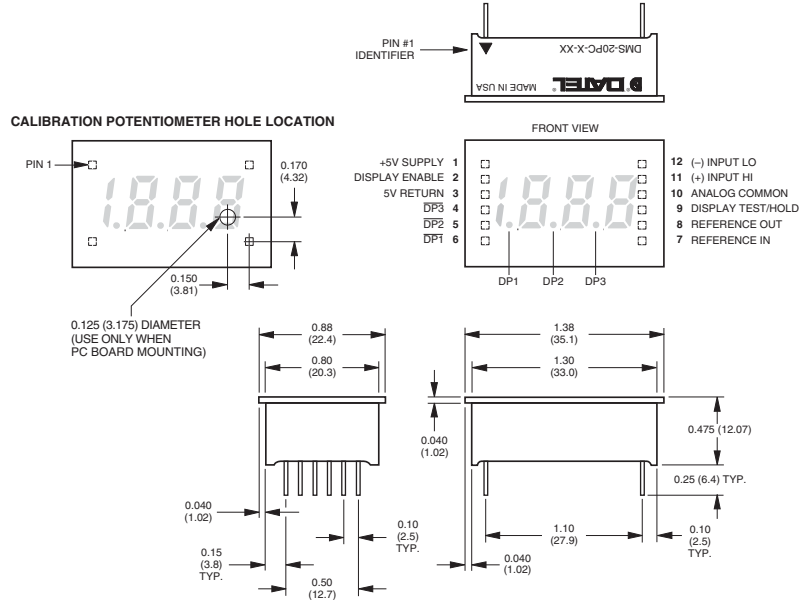

Figure 10. External Gain Adjustment

MECHANICAL SPECIFICATIONS

MECHANICAL DIMENSIONS: Inches (mm)
 TOLERANCES: 2 PL DEC ±0.02 (±0.51)
 3 PL DEC ±0.010 (±0.254)
 LEAD DIMENSIONS: 0.025 (0.635) x 0.025 (0.635) NOMINAL
 RECOMMENDED PC BOARD FINISHED HOLE DIAMETER:
 0.042 ±0.003 (1.067 ±0.076)



BEZEL INSTALLATION AND RECOMMENDED DRILL AND PANEL CUTOUT

