



FEATURES

- Measures the rms value of complex ac voltages
- Three input ranges: 20Vac, 200Vac and 300Vac
- Two operating-supply options: 85-264Vac, or +10-40Vdc
- Input circuit fully isolated from operating power supply
- 47-1kHz input frequency range
- Fully encapsulated plastic package measures 1.38" x 0.88" (35mm x 22.4mm)
- Large, easy-to-read, red LED display is visible from 12 feet (4m)

Murata Power Solutions' DMS-20RM series are four-wire, self-contained ac voltmeters that measure and display the true-rms values of complex ac waveforms. Because the input circuitry is electrically isolated from the unit's operating power source, these voltmeters can measure signals down to zero volts. No external isolation transformers or auxiliary power supply conditioning components are required. Simply connect the input signal and a source of operating power (85-264Vac, or an optional +10-40Vdc) to the two rear-mounted terminal blocks and the unit is fully operational.

DMS-20RM rms voltmeters are available in a choice of three input ranges: 20Vac (with 0.01V resolution); 200Vac (0.1V resolution); and 0-300Vac (1V resolution). An input frequency range of 47-1kHz makes these voltmeters ideal for all ac voltage monitoring applications. And, unlike conventional, average-responding products, these meters can measure and accurately display the true-rms value of triangle waves, square waves, or other irregularly shaped waveforms with 0.4% full-scale accuracy.

The large (0.37"/9.4mm), bright red LED display makes the DMS-20RM ac voltmeters easily readable from as far as 12 feet (4 meters). All units are packaged in a red-filter case with a built-in bezel; these meters are fully encapsulated to make them moisture and vibration resistant. Their miniature size is perfect for high-end consumer electronics, laboratory instrumentation, alternative power generators and other products requiring precise ac line monitoring.

TYPICAL WIRING DIAGRAMS

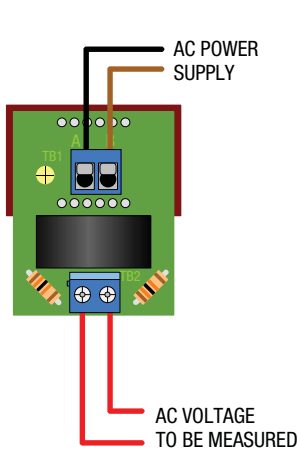

Figure 1A.

Powered by AC supply while measuring separate AC signal.

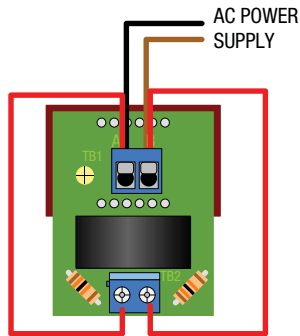

Figure 1B.

Powered by and measuring the same AC power source.

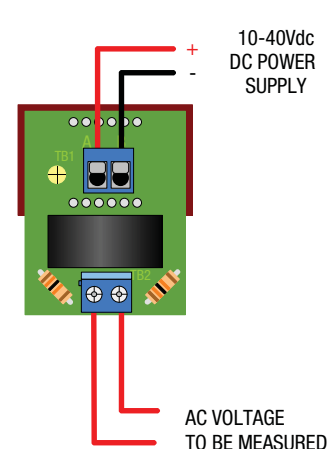

Figure 2.

Powered by DC power supply while measuring AC signal.



For full details go to
www.murata-ps.com/rohs

Performance/Functional Specifications

Typical at TA=+ 25°C with 60Hz sine-wave input, unless otherwise noted

Full-Scale Input Voltage (TB2)	Min.	Typ.	Max.	Units
DMS-20RM-1	0	—	19.99	Vac
DMS-20RM-2	0	—	199.9	Vac
DMS-20RM-3	0	—	300	Vac
Frequency Range	47	60	1000	Hz
Performance				
Sampling Rate	2.5 reading per second			
Accuracy ①	±0.4%FS ±2 counts with 60Hz sine wave input			
Measurement Type	rms responding, Crest Factors of 1-5			
Temperature Drift (0 to 60°C)		±0.2	±0.4	Counts/°C
Zero-Volt Reading (within 30 sec.)	-001	000	001	Counts
Breakdown Voltage, TB1 to TB2	2000	—	—	Vdc
Power Supply Voltage (TB1)				
DMS-20RM-X-AC1	85	—	264	Vac/47-63Hz
DMS-20RM-X-DC2	+10.0	—	+40.0	Vdc
Power Supply Current (TB1, ②)				
DMS-20RM-X-AC1	—	30	50	mA/47-63Hz
DMS-20RM-X-DC2	—	10	15	mAdc
Terminal Block Wiring (TB1 and TB2)				
Wire Size	16-22AWG, Solid or stranded			
Insulation Strip Length	0.250 inches			
Screw Tightening Torque	3.6 pound-inches (0.4Nm)			
Rated Voltage	300Vac			
Display				
Display Type and Size	3½ Digit LED, 0.37"/9.4mm high			
Overrange Indication	"1 ___"			
Decimal Point	Fixed, model dependent (see full-scale input voltage above)			
Physical/Environmental				
Operating Temperature	-25	—	+60	°C
Storage Temperature	-40	—	+75	°C
Humidity (non-condensing)	0	—	85	%
Dimensions	Model dependent; see product datasheet.			
Weight:	1.3 Ounces (36 grams) nominal			

① Specified accuracy applies to inputs with crest factors (CF) up to 2.0, where CF = Vpeak/Vrms. Crest factors of 2 to 5 introduce an additional error of ±3% of full scale. Voltmeters are calibrated with a near full-scale, 60Hz sine-wave input.

② Specified maximum power supply currents are steady state; larger surge currents can occur at initial application of power.

ORDERING INFORMATION

DMS-20RM-1-AC1-R-C	0 to 19.99Vac, AC Powered
DMS-20RM-2-AC1-R-C	0 to 199.9Vac, AC Powered
DMS-20RM-3-AC1-R-C	0 to 300Vac, AC Powered
DMS-20RM-1-DC2-R-C	0 to 19.99Vac, DC Powered
DMS-20RM-2-DC2-R-C	0 to 199.9Vac, DC Powered
DMS-20RM-3-DC2-R-C	0 to 300Vac, DC Powered

IMPORTANT! To ensure safe and reliable operation, DMS-20RM ac voltmeters must be installed and serviced by qualified technical personnel. Contact Murata Power Solutions if there is any doubt regarding installation and/or operation.

TECHNICAL NOTES

- 1. Measurement Type:** DMS-20RM series ac voltmeters employ a precision rms-to-dc converter and a high-precision voltage reference to measure and display the rms value of complex ac waveforms. Please note, the rear-mounted potential transformer is used to isolate the input signal being measured (TB2) from the ammeter's operating power source connected to TB1. Do not pass any conductors through this transformer's center hole as this will introduce significant measurement errors.
- 2. Wiring:** All power supply and input signal wiring must be rated for the voltages and currents they will carry and must comply with any code or application-mandated requirements pertaining to the user's specific installation.
- 3. Power Supply Polarity, Fusing, and Grounding:** As shown in Figures 1A and 1B, the two power supply inputs, TB1-A and TB1-B, on ac-powered DMS-20RM voltmeters ("-AC1" suffix) are not polarity sensitive, that is, they have no "AC LO" or "AC HI" designations. Also, ac-powered models do not include or require a connection to earth/chassis ground. DC-powered models ('-DC2' suffix) are reverse-polarity protected, and must be connected as shown in Figure 2 for proper operation.
DMS-20RM ac voltmeters are not internally fused. If fusing is required it must be externally installed according to the supply wire's maximum amperage rating.
- 4. Calibration:** Periodic recalibration of DMS-20RM voltmeters is not required under normal, indoor operating environments. If calibration is necessary, it should only be performed by qualified technical personnel. Calibration is performed with potentially lethal voltages applied to the DMS-20RM and its associated wiring. A plastic, fully-insulated adjusting tool must be used to access the recessed calibration potentiometer located on the back of the unit (see Mechanical Specifications). Contact Murata Power Solutions if additional information is required regarding calibration, setup, or any other technical issue pertaining to DMS-20RM ac voltmeters.

MECHANICAL SPECIFICATIONS

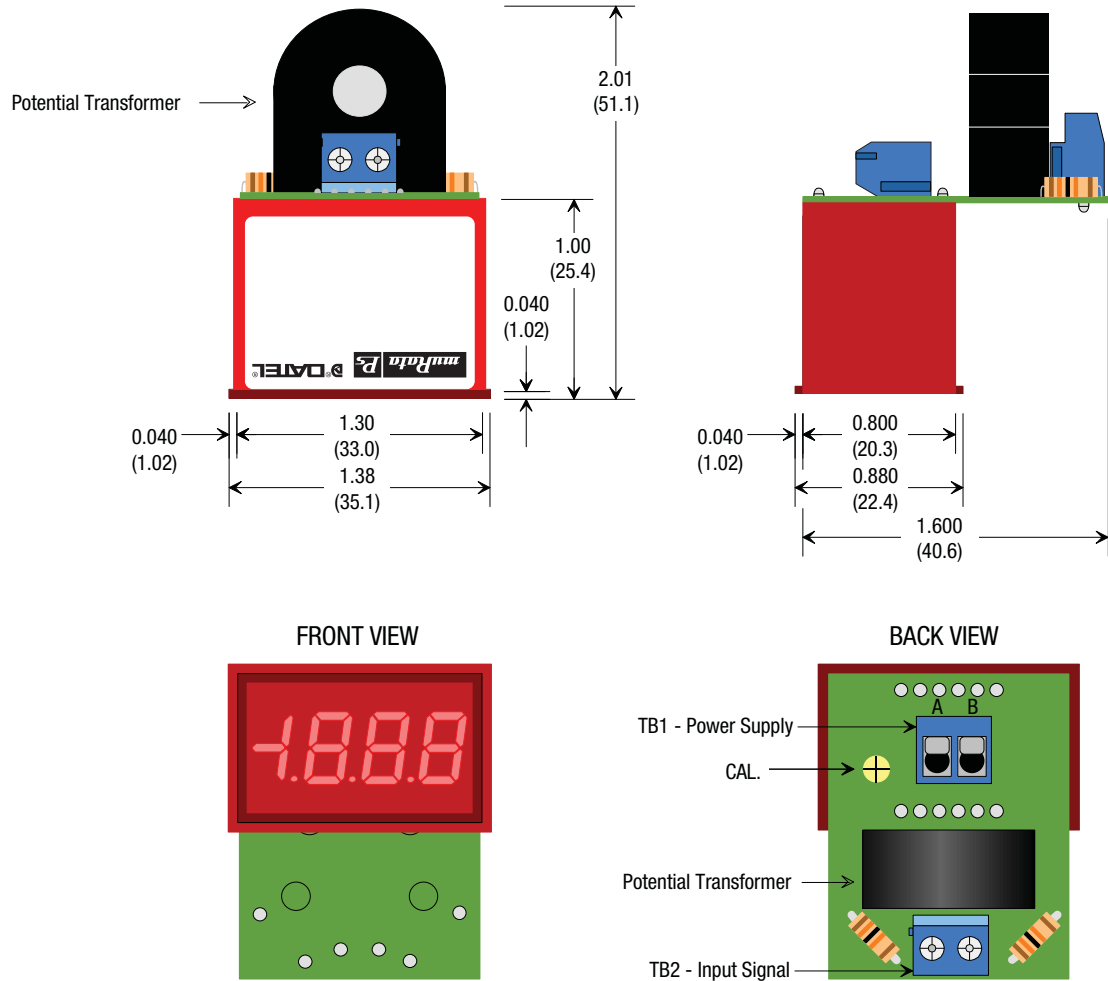

RECOMMENDED DRILL AND PANEL CUTOUT

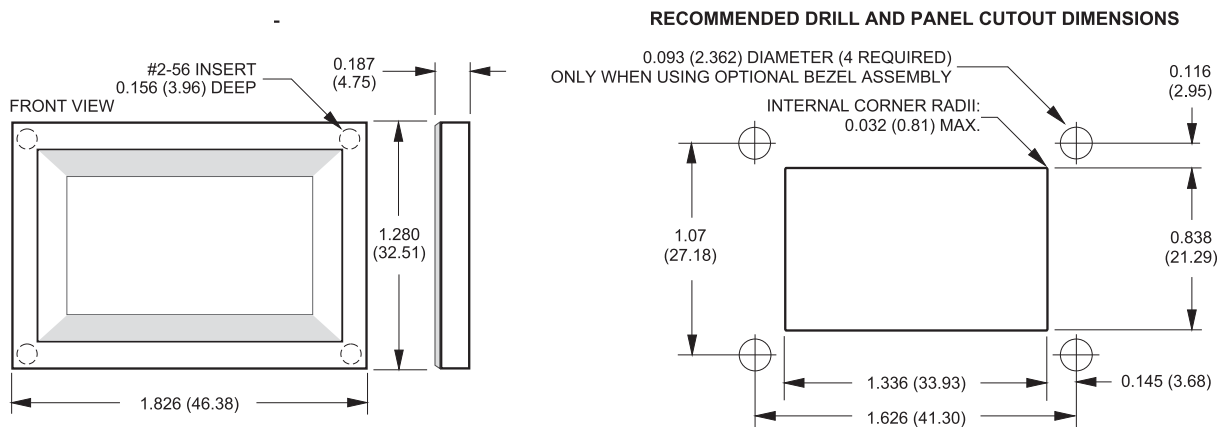

Panel Installation

All connections to DMS-20RM ac voltmeters must be made after the meter is securely attached to the panel, with all associated ac supply power sources de-energized (off). The installed wire positions should be such that minimal forces are applied to terminal blocks TB1 and TB2. In high-vibration environments, proper strain reliefs must be used for all wiring.

To ensure a secure panel-mount installation, MPS recommends using the DMS-BZL4-C bezel assembly (with sealing gasket) supplied with each DMS-20RM voltmeter. See the 'Mechanical Specifications' section for detailed cutout and voltmeter dimensions.

Following the four-step sequence shown in Figure 3 — being careful not to apply excessive force or twisting motions — insert the DMS-20RM into the panel opening. When using the DMS-BZL4-C, install its sealing gasket so it is positioned between the voltmeter's front flange and panel front surface (see Mechanical Specifications). Be sure to use and securely tighten all four screws supplied with the bezel assembly.

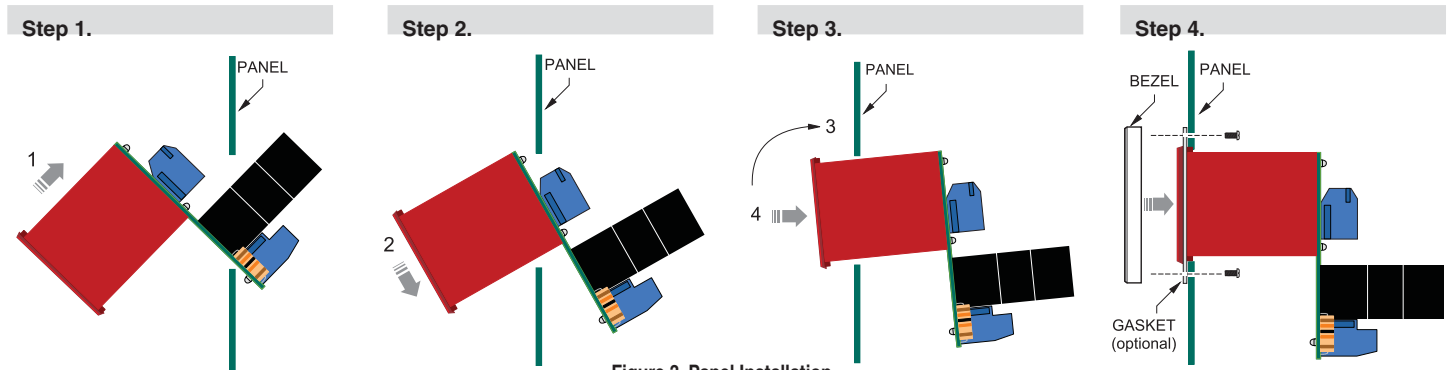

Figure 3. Panel Installation