

FEATURES

- Balanced differential inputs, 5 pA bias current, autozeroing with 80 dB CMR noise rejection
- 1000 MΩ CMOS high impedance inputs, ±1.999 V dc FS range
- 3½ digits, 56" high LED displays, 5V-powered, ratiometric reference for drift correction
- Internal user-options:
 1. Accepts shunts for ±20 μA to ±2A FS ranges
 2. Accepts attenuators for ±2V to ±1KV FS ranges
 3. Digital ohmmeter, 200Ω to 10 MΩ, FSR
- Compact, short depth case measures only 3.00"W × 2.15"D × 1.76"H (76,2 × 54,6 × 44,7 mm).



GENERAL DESCRIPTION

The DM-3100L is a 3½ digit Digital Panel Meter which uses solid-state self-illuminated, light-emitting diode (LED) display. Its large size (0.56" high) and brilliant red light make it easily readable from many feet away. This DPM is contained in a very small short depth case (3.00"W × 2.15"D × 1.76"H) which makes for easy installation in shallow test panels. Besides measuring DC voltages, the user may install internal components to make resistance and current readings. The decimal point can also be externally selected by jumpering selected pins together. The versatility of this meter is further enhanced by its autozeroing capabilities.

The DPM DM-3100L accepts a dc or slowly-varying input voltage between -1.999V and +1.999 and displays that input on front panel numerical indicators. It employs a conventional dual-slope A/D converter plus 7 segment display decoder-drivers all in one LSI microcircuit. Since this microcircuit requires approximately 10V to power the A/D section, an internal DC/DC converter generates -5VDC from +5V power input to form a bipolar power supply.

Another feature of the DM-3100L is that it employs a bal-

anced differential input. When used with a bridge or transducer input, it offers high noise immunity and can accurately measure very small signals in the presence of much larger common mode signals.

Another characteristic of this balanced differential input is that, due to the high input impedance, 1000 megohms, the DPM will not load down sensitive input circuits.

A very noteworthy feature of this meter is that it can be operated ratiometrically. This means that it has internal circuits that can automatically compensate for reference drifts in the supplies of balanced bridge or transducer sensors.

The DM-3100L finds use in analytical instruments, industrial process controllers, portable diagnostic instruments, automatic test equipment, medical and patient monitoring instruments, airborne, marine and ground vehicles and data acquisition/data logging systems.

Open PC board pads are provided to accept user-supplied input voltage attenuators, current shunts or digital ohmmeter components.

SIMPLIFIED BLOCK DIAGRAM

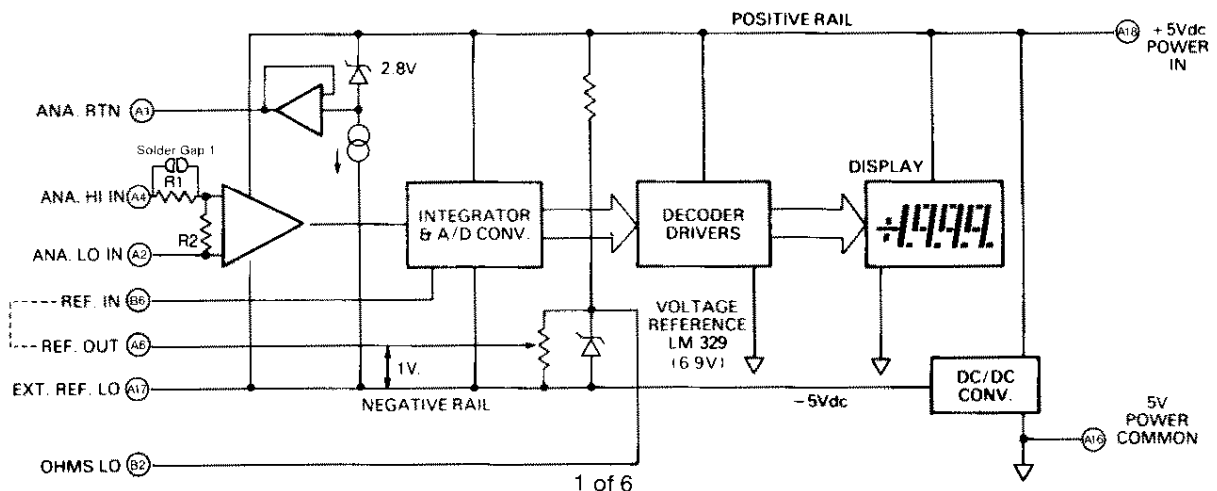

SPECIFICATIONS DM-3100L (Typical @ +25°C unless noted)

ANALOG INPUT		Display Enable (Pin B18)	Connect to +5 Vdc power to illuminate display. Disconnect to blank display but keep A/D converter cycling.
Configuration	True, balanced differential bipolar	Display Test (Pin B14)	Connect this input to +5Vdc to light all display segments.
Full Scale Input Range	-1.999 Vdc to +1.999Vdc Input pad area will accept user-installed range change	Polarity Enable (Pin B16)	Ground this input to automatically display a minus sign for negative inputs.
Input Bias Current	5 pA typical, 50 pA maximum	Ohms Lo (Pin B2)	This connection is used in the ohmmeter configuration, otherwise do not use.
Displayed Accuracy @ +25°C	Adjustable to ±0.1% of reading, ±1 count	POWER CONNECTIONS	
Resolution	1 mV	+5 VDC Power IN (Pin A18) ..	Connect this pin to +5 Vdc regulated to power the A/D converter and displays.
Temperature Drift of Zero	Autozeroed ±1 count over 0 to +50°C	5V Power Common (Pin A16) ..	This pin may be used as a bias current return path for some inputs. Connect to Power Ground.
Temperature Drift of Gain	±50 ppm of Reading/°C typ. ±100 ppm of Reading/°C max.	POWER REQUIREMENTS	
Input Impedance	100 Megohms, minimum	External +5, ±0.25 Vdc regulated required at 280 mA typical, 450 mA max. Logic spikes must not exceed 50 mV. Power current varies rapidly so that unregulated supplies cannot be used.	
Input Overvoltage	± 250 Volts dc 175 VRMS continuous max. ±300 Volts intermittent max.	Calibration	A multiturn screwdriver pot adjusts the full scale reading (gain). Zero is automatic (autozeroing). Suggested recalibration in stable conditions is 90 days.
Common Mode Rejection	80 dB, DC to 60 Hz, 1 Kilohm unbalance	PHYSICAL-ENVIRONMENTAL	
Common Mode Voltage Range	Within +Vs -5V and -Vs +1V where +Vs is the positive rail (Pin A18) and -Vs is the negative rail (Pin A17) -Vs is approximately equal to -5V below PWR. COM.	Short-Depth Case	Interchangeable with other Datal-Intersil cases
Warm-up Time	Within 10 minutes	Outline Dimensions	3.00"W × 2.15"D × 1.76"H (76.2 × 54.6 × 44.7 mm)
Reference	Internal, referred to the negative rail (-Vs). External, user-supplied reference optional for ratiometric operation.	Cutout Dimensions	1.812"H × 3.062"W (46.0 × 77.7 mm)
External Ref. Range	+100 mV to +2V, referred to -Vs	Mounting Method	Through a front panel cutout secured by (4) 4-40 front access screws which are concealed by the bezel.
Ramp-up Time (Integration Period)	83.3 mS.	Weight	Approximately 5 ounces (142g)
DISPLAY		Connector	Double-sided edgeboard PC type, solder tab, gold-plated fingers. Dual 18-pin, 0.100" centers.
Number of Digits	3 decimal digits and most significant "1" digit (3½ digits)	Mounting Position	Any
Decimal Points	Selectable decimal points are included for scale multipliers.	Operating Temperature Range ..	0 to +50 °C
Display Type	Red, light-emitting diode (LED) self illuminated.	Storage Temperature Range ..	-25 to +85°C
Display Height	0.56 inches (14,2 mm)	Altitude	0 to 15,000 feet (4900m)
Overscale	Inputs exceeding the full scale range blank the display, leaving a "1" MSD and sign	Relative Humidity	20% to 80% non-condensing
Autopolarity	A minus sign is automatically displayed for negative inputs, and may also be blanked	Ordering Information	
Sampling Rate	Factory set at 3 conversions per second. May be rewired up to 20 conversions/second.	DM-3100L-1: ± 2Vdc Input Range (Supplied With Free Connector)	
I/O CONNECTIONS		RN-3100/4100: Range-Change Accessory Kit for DM-Series Meters	
Analog HI Input (Pin A4)	Differential input voltages are connected between these inputs.		
Analog LO Input (Pin A2)	A bias current path to POWER COMMON (if 5V-powered) or ANALOG RETURN from both these inputs must be externally provided. External circuits must constrain these inputs to be within the common mode voltage range.		
Analog Return (Pin A1)	This pin may be used as a low-noise bias current for some floating inputs. If not possible, inputs may be referenced to POWER COMMON (if 5V-powered). Analog Return is approximately -2.8V below +Vs and can sink 30 mA to -Vs.		
Reference In/Out (Pins B6/A6)	Normally, REF. IN and REF. OUT should be jumpered together. An external floating source referred to EXT. REF. LO (Pin A17) may be substituted for ratiometric operation.		
Decimal Points	Connected selected pin to DECIMAL POINT COMMON (Pin B15)		

DM-3100L COMPONENT LOCATIONS *

FOR OTHER VOLTAGE AND CURRENT RANGES			
F.S. RANGE	1, 2 R1	1, 2 R2	DECIMAL POINT
±2V	Short SG1	Omit	A10 to B15
±20V ³	10 MΩ ⁴	1.1 MΩ ⁴	A11 to B15
	or 9.1 MΩ	or 1 MΩ	A11 to B15
±200V ³	10 MΩ	100 KΩ	A12 to B15
±1000V	10 MΩ ⁴	10 KΩ	A13 to B15
±200 mA	Short SG1	10Ω, 1W	A12 to B15
±20 mA	Short SG1	100Ω, 1/4W	A11 to B15
±2 mA	Short SG1	1 KΩ	A10 to B15
±200 μA	Short SG1	10 KΩ	A12 to B15
±20 μA	Short SG1	100 KΩ	A11 to B15

NOTES:

(1) R1, R2 ARE USER-INSTALLED ATTENUATION OR (R2) SHUNT RESISTORS. BEFORE INSTALLING RESISTORS AT R1, OPEN SOLDER GAP (SG1) ON ETCH SIDE OF BOARD WITH A SOLDERING IRON. NOTE THAT IF R1 IS LATER REMOVED, THE USER MUST CLOSE THE SOLDER GAP.

(2) R1 AND R2 FOR VOLTAGE RANGES ARE RN80C EXCEPT RN70C. CURRENT SHUNTS SHOULD BE 1%, 10 PPM/°C OR BETTER. 1W AND 1/4W RESISTORS MAY NOT FIT FLUSH TO BOARD.

(3) THESE RANGES REQUIRE ADJUSTMENT OF R8 FOR ACCURATE READINGS.

(4) IF 10 MΩ IS NOT AVAILABLE, USE R1 = 2 MΩ, R2 = 220 KΩ.

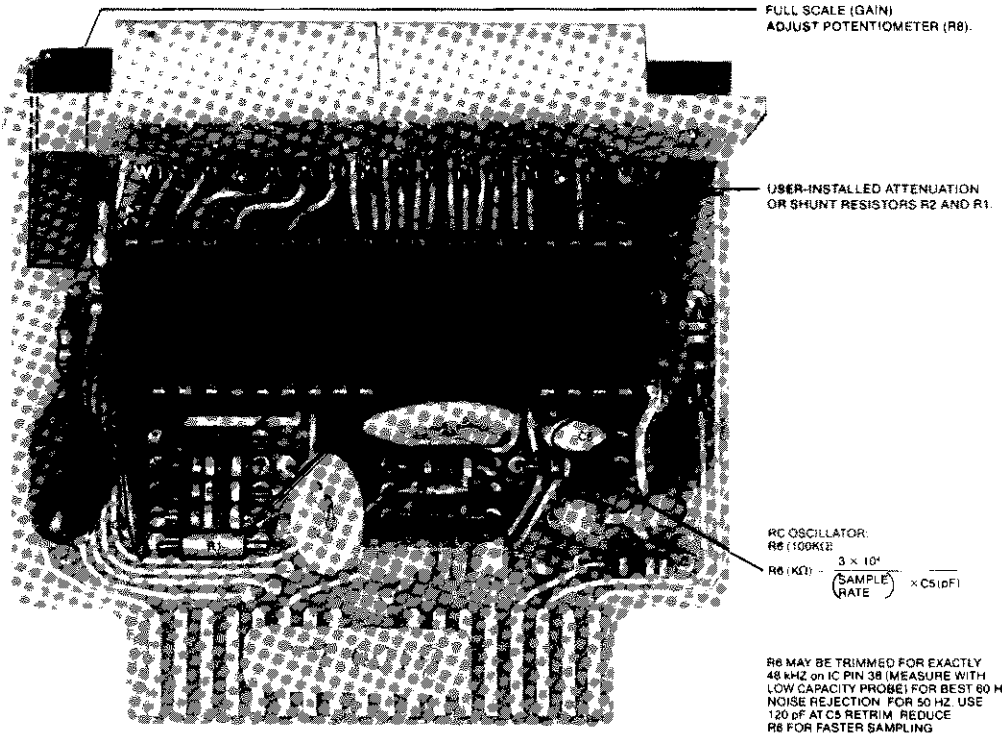

* Refer to DATEL RN-3100/4100 Range-Change Accessory Kit data sheet for detailed modification instructions and R1 & R2 locations.

INPUT/OUTPUT CONNECTIONS WITH SINGLE-ENDED INPUT

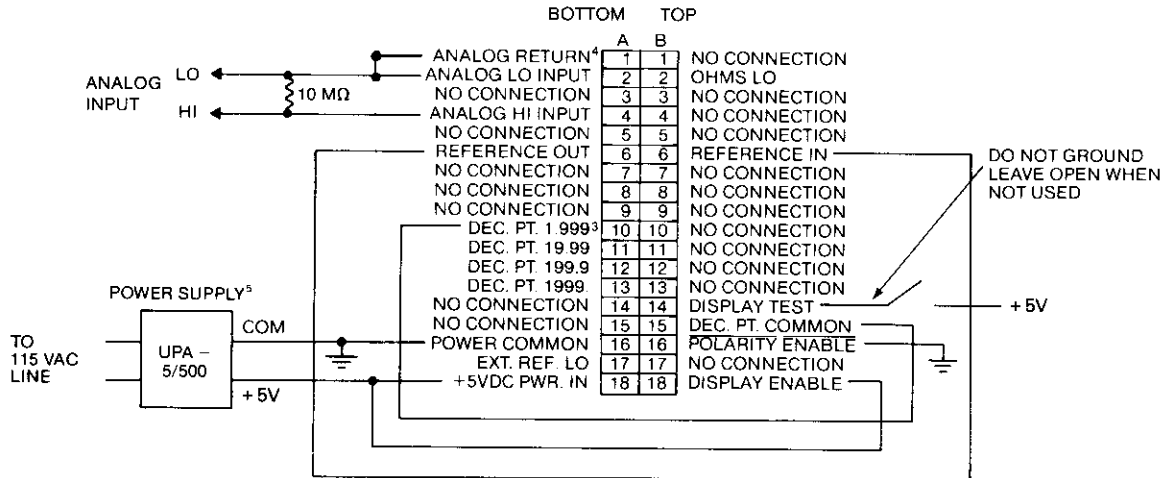

NOTES:

- This shows the connector rear view with the DPM tilted on its side.
- CAUTION: This DPM employs high impedance CMOS inputs. Although internal protection is provided for several hundred volt overloads, this DPM will be destroyed by kilovolts of static discharge which is especially prevalent in low humidity environments. Always handle the DPM with ground protection.
- DO NOT CONNECT DECIMAL POINT TO POWER COMMON as this will destroy the decimal point.
- ANALOG RETURN = +Vs - 2.8 Vdc.
- The UPA-5/500 Power Supply is a user-supplied, user installed DATEL-INTERSIL accessory.

MECHANICAL DIMENSIONS INCHES (mm)

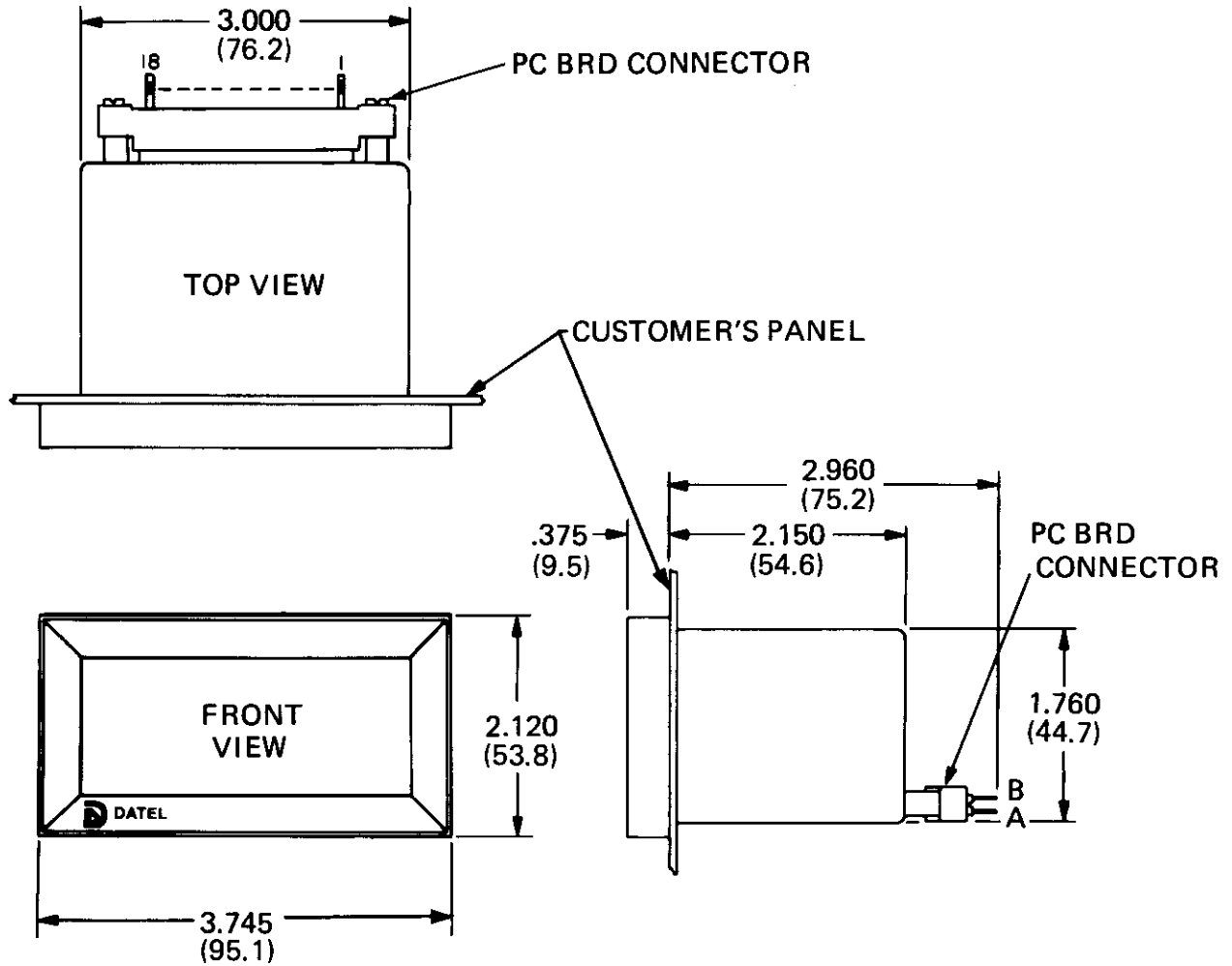

DWG. C-1561-4

PANEL MOUNTING

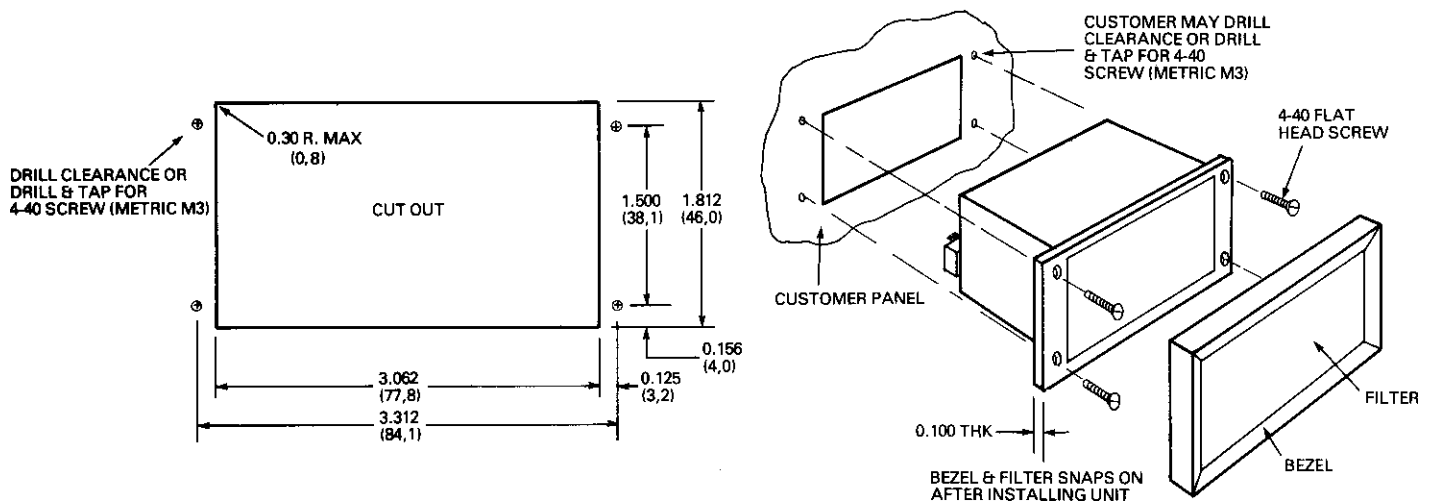

DIFFERENTIAL INPUT WITH SAMPLE RATIO-METRIC CONNECTIONS

The DM-3100L has a reference in-out loop which makes possible ratiometric measurements. Representative connections are illustrated below. Ratiometric operation eliminates changes in the DPM reading due to voltage variations in the Bridge's external excitation source. The input gain on the DM-3100L varies inversely with voltage at Reference In — as REF IN voltage increases, meter gain decreases. Meter input gain thus can be made to compensate for variations in the bridge excitation source voltage. (The DPM is set for unity gain when REF IN V equals +1V as referred to EXT. REF. LO).

For all applications, $V_{IN} = 2 V_{REF}$ at full scale (1999 counts). For small values of V_{REF} (100 mV or lower), increased display noise, nonlinearity, rollover and CMR errors will be apparent. Avoid V_{REF} inputs beyond about 2V to prevent integrator satu-

ration with full scale inputs. Variable V_{REF} is not intended for wide gain changes as in multimeter applications. Instead, it should be used for drift correction, scaling to engineering units, or for modest amounts of gain.

A note on grounding: The DM-3100L's internal voltage reference source is biased against the internal negative supply rail (EXT. REF. LO). Note that this is *not* the same electrical connection as the 5V Power Common connection. Refer to the Simplified Block Diagram.

Because of this configuration, external reference sources should be isolated from the 5V Power Common and should have the Reference Lo Output from the external source connected to the negative supply rail.

DM-3100L

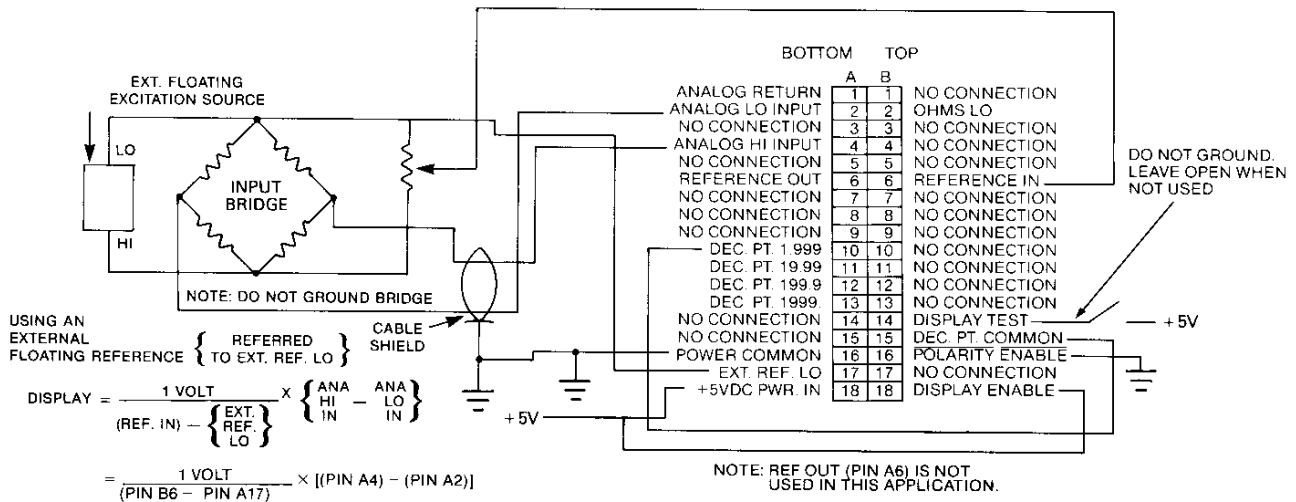

DIGITAL OHMMETER CONNECTIONS

The digital ohmmeter circuit uses the DM-3100L's ratiometric capability. An external reference resistor of known resistance, accuracy, and temperature drift is connected in series with the unknown resistance. A constant, stable voltage from

the DPM's internal reference diode is applied to the resistor pair to produce a constant current. This current develops two voltage drops across the resistors which are proportional only to the ratio of the resistances since the current through them is identical.

The chart below lists recommended R_{REF} and R_{LIMIT} resistance values corresponding to different ohmmeter ranges. Values of R_{LIMIT} were selected to limit the current through R_{REF} and R_x to 1 milliamper maximum.

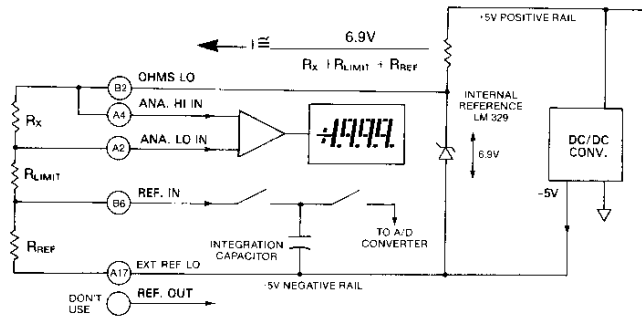

$$\text{DISPLAY} = \frac{E_{IN}}{V_{REF}} \times 1V = \frac{I R_x}{I R_{REF}} \times 1V = \frac{R_x}{R_{REF}} \times 1V$$

RANGE	RESOLUTION	R_{LIMIT}^1	R_{REF}^1	DECIMAL POINT
19.99 MΩ	10 kΩ	22 MΩ	10 MΩ	A11 to B15
1.999 MΩ	1 kΩ	3.6 MΩ	1 MΩ	A10 to B15
199.9 kΩ	100 Ω	360 kΩ	100 kΩ	A12 to B15
19.99 kΩ	10 Ω	36 kΩ	10 kΩ	A11 to B15
1.999 kΩ	1 Ω	6.2 kΩ	1 kΩ	A10 to B15

1. R_{LIMIT} and R_{REF} should be metal film, High Stability Resistors (AS RN60C).