

# Signals with Zero Offsets

## Introduction

Many transducer outputs exhibit a dc offset voltage when the output level would normally be expected to be zero Volts (corresponding to a display reading of "000"). As an example, consider a pressure transducer whose output levels of 1.0Vdc to 6.0Vdc are required to produce display readings of "000" to "400" respectively. To obtain the desired readings, the 1-6V signal has to be attenuated first, and then its 1V offset voltage must be subtracted or nulled to zero.

## Attenuating the Input

The resistor divider shown in Figure 1 easily accomplishes the task of reducing the raw input signal ( $V_{IN}$ ) down to a level which a  $\pm 2V$ -input meter (DMS-30PC-1-RS for example) can accept. However, the attenuated signal ( $V_{atten}$ ) at pin 11 (+) INPUT HI still has a dc offset which has to be nulled. The following procedure can be used with many other input-voltage/display-reading combinations. Two completely worked-out examples will be provided.

The DMS-EB Application Board for DMS-30 Series meters has locations for installing the required user-supplied components shown in Figures 1 and 2. For large OEM requirements, DATEL can provide a completely wired and tested meter to suit your particular requirements. Please consult our sales or marketing engineers for more information.

**Example 1.** A 1-6V input signal must be conditioned to display "000" to "400".

Step 1. Find the differential input voltage  $V_{IN}(\text{diff})$ :

$$V_{IN}(\text{diff}) = V_{IN}(\text{max}) - V_{IN}(\text{min})$$

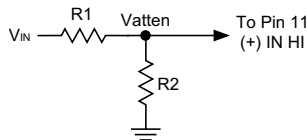

Figure 1. Resistor Divider

Where  $V_{IN}$  is the raw input voltage (1V to 6V) and  $V_{IN}(\text{diff})$  is the differential raw input voltage. In this example,  $V_{IN}(\text{max}) = 6V$  and  $V_{IN}(\text{min}) = 1V$ . The result is as follows:

$$V_{IN}(\text{diff}) = 6V - 1V = 5V$$

Step 2. Use the required display readings for  $V_{IN}(\text{min})$  and  $V_{IN}(\text{max})$  to find  $V_{atten}(\text{diff})$ :

In this example, when  $V_{IN}(\text{min}) = 1V$ , the display must read "000", and when  $V_{IN}(\text{max}) = 6V$ , the display must read "400". The following equation defines  $V_{atten}(\text{diff})$ :

$$V_{atten}(\text{diff}) = V_{atten}(\text{diffhi}) - V_{atten}(\text{difflo})$$

Where  $V_{atten}(\text{diffhi})$  and  $V_{atten}(\text{difflo})$  are the respective high and low differential voltages (measured between the meter's pins 11 and 12) needed for the highest display reading (0.400V to read "400") and the lowest display reading (0.0V to read "000"), assuming a meter with a  $\pm 2V$  input range is used.

$$V_{atten}(\text{diff}) = V_{atten}(\text{diffhi}) - V_{atten}(\text{difflo})$$

$$V_{atten}(\text{diff}) = 0.400V - 0.000V = 0.400V$$

Step 3. Find the input attenuator ratio  $r$ , and then use  $r$  to find  $R2$  (see Figure 1):

$$r = V_{atten}(\text{diff}) / V_{IN}(\text{diff})$$

Substitute the previously calculated values for  $V_{atten}(\text{diff})$  and  $V_{IN}(\text{diff})$ :

$$r = 0.400V / 5V = 0.08$$

Assuming  $R1 = 909k\Omega$  and using the calculated value of 0.08 for  $r$ , solve the equation below to find  $R2$ :

$$R2 = [r / (1 - r)] \times R1$$

$$R2 = [0.08 / (1 - 0.08)] \times 909,000 = 79,043\Omega$$

The nearest  $\pm 1\%$  resistor is 78.7k $\Omega$ . The assumed  $R1$  value of 909k $\Omega$  is an arbitrary one, however, it does keep the attenuation circuit's impedance near 1M $\Omega$  and should reduce any loading the meter may have on the input signal source ( $V_{IN}$ ).

Step 4. Find the null voltage that must be applied to pin 12 (-) INPUT LO, see Figure 2):

Please note that all voltages in this step are single-ended values (measured with respect to pin 3, 5V RETURN). The primary goal of this step is to illustrate that all the calculations above actually work! The following two equations will be used:

$$V_{atten(max)} = r \times V_{IN(max)} \text{ and } V_{atten(min)} = r \times V_{IN(min)}$$

Substituting values produces the following results:

$$V_{atten(min)} = 0.08 \times 1.0V = 0.08V, \text{ and}$$

$$V_{atten(max)} = 0.08 \times 6.0V = 0.480V$$

When  $V_{IN}$  is 1V,  $V_{atten(min)}$  will be 0.08V. It must be nulled by also placing 0.080V on pin 12 (-) INPUT LO) in order to achieve a display reading of "000". The circuit shown in Figure 2 uses a precision 22-turn potentiometer (R5) to generate 0.08V of zero offset.

When  $V_{IN}$  is 6V,  $V_{atten}$  will be 0.48V, however, the meter will display the difference between pins 11 and 12:  $0.48V - 0.08V = 0.400V$  (a reading of "400").

Step 5. Calibrate the circuit:

Apply a 1.0V input ( $V_{IN}$ ) and adjust R5 (zero adjust) so the display reads "000". Apply 6.0V and adjust R4 (gain adjust) so the display reads "400". The decimal points (DP1-DP3) have not been mentioned above because they are strictly place holders.

**Example 2.** A 1-5V input must display "200" to "1200".

Step 1. Find the differential input voltage  $V_{IN}$  (diff):

$$V_{IN(diff)} = V_{IN(max)} - V_{IN(min)}$$

$$V_{IN(diff)} = 5V - 1V = 4V$$

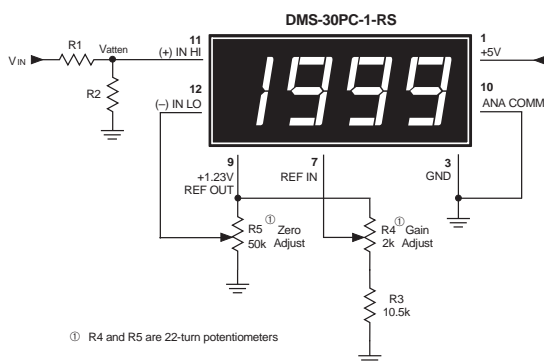

Figure 2. Schematic Diagram

Step 2. Use the required display readings for  $V_{IN(min)}$  and  $V_{IN(max)}$  to find  $V_{atten(diff)}$ :

In this example, when  $V_{IN(min)} = 1V$ , the display must read "200", and when  $V_{IN(max)} = 6V$ , the display must read "1200":

$$V_{atten(diff)} = V_{atten(diffhi)} - V_{atten(difflo)}$$

$$V_{atten(diff)} = 1.200V - 0.200V = 1.000V$$

Recall that  $V_{atten(diffhi)}$  is the differential voltage between pins 11 and 12 required to display "1200", and  $V_{atten(difflo)}$  is the differential voltage which will display "200".

Step 3. Find the input divider ratio  $r$ , and then use  $r$  to find R2:

$$r = V_{atten(diff)} / V_{IN(diff)}$$

$$r = 1V / 4V = 0.25$$

Again, assuming  $R1 = 909k\Omega$ , find R2:

$$R2 = [r / (1 - r)] \times R1$$

$$R2 = [0.25 / (1 - 0.25)] \times 909,000 = 303,000\Omega$$

The closest  $\pm 1\%$  resistor is 301k $\Omega$ .

Step 4. Find the null voltage that must be applied to (-) INPUT LO (pin 12):

$$V_{atten(min)} = r \times V_{IN(min)} \text{ and } V_{atten(max)} = r \times V_{IN(max)}$$

Substituting values gives the following results:

$$V_{atten(min)} = 0.25 \times 1V = 0.25V, \text{ and}$$

$$V_{atten(max)} = 0.25 \times 5V = 1.25V$$

If we examine the min. and max.  $V_{atten}$  values above, 0.250V and 1.250V, we notice that they are only 0.05V above the desired display readings of "200" (or 0.200V) and "1200" (or 1.200V). The required zero-offset voltage will be near, but not exactly, 0.05V.

Step 5. Calibrate the circuit:

The calibration of this example differs from the procedure used in Example 1. In this application, the offset potentiometer (R5) and the gain potentiometer (R4) interact with one another. It is very important to perform the calibration in the sequence presented below.

First, apply a 1.0V input and adjust R5 to its maximum clockwise or counterclockwise position in order to obtain the highest positive display reading (approximately "240" in this example). Next, apply a 5.0V input and adjust the gain potentiometer R4 so the display reads exactly "1250". Then, apply a 1.0V input and adjust R5 so the display reads exactly "200". Lastly, apply a 5.0V input. The display should now read "1200". Re-apply both  $V_{IN}$  settings (1V and 5V) to make sure the adjustments did not adversely affect one another. Perform minor adjustments if necessary. This ap note for NGT.



DATEL, Inc. 11 Cabot Boulevard, Mansfield, MA 02048-1151  
Tel: (508) 339-3000 (800) 233-2765 Fax: (508) 339-6356  
Internet: www.datel.com Email: sales@datel.com  
Data sheet fax back: (508) 261-2857

DATEL (UK) LTD. Tadley, England Tel: (01256)-880444  
DATEL S.A.R.L. Montigny Le Bretonneux, France Tel: 01-34-60-01-01  
DATEL GmbH München, Germany Tel: 89-544334-0  
DATEL KK Tokyo, Japan Tel: 3-3779-1031, Osaka Tel: 6-354-2025