

# Input Configurations, Power Supplies and Ground Loops

## Single-Ended Inputs

Single-ended and differential inputs, though no different for digital meters than any other application, are always worth revisiting. Please refer to Figure 1, the simplified schematic for the DMS-30LCD 3½ digit DPM during the following discussion.

All input signals must effectively be applied to each meter's two input terminals: a "positive" (high-side) input and a "negative" (low-side) input. These connections are normally made to the meter's pin 11, (+) INPUT HI, and pin 12, (-) INPUT LO. A single-ended signal will always have one of these two input pins connected to, or at the same potential as, pin 3 (5V RETURN/- BATTERY). The +5V power supply itself is an obvious example of a single-ended signal (see Figures 2 and 3).

## Differential Inputs

A differential input signal is one that has both inputs at potentials other than that applied to pin 3 (5V RETURN/-BATTERY). For example, the low input terminal (pin 12) could be at -1Vdc and the high input terminal (pin 11) at +0.9Vdc. Please note that in these instances, all voltages should be measured with an isolated voltmeter that has its negative lead (the black one) tied to pin 3 (0Vdc).

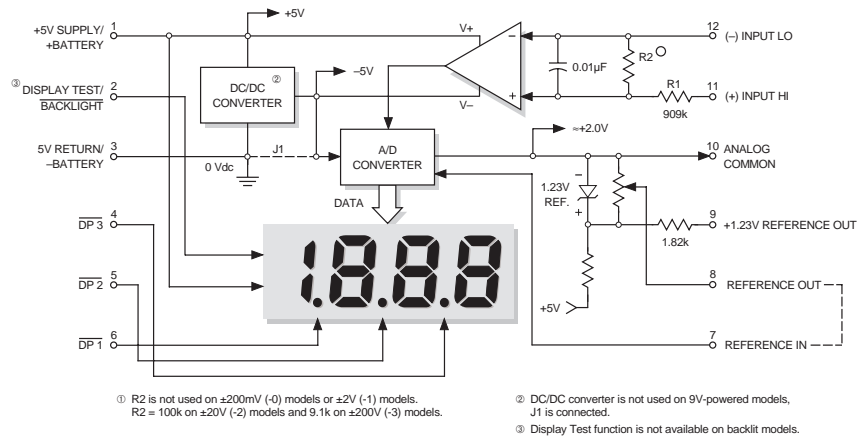

Figure 1. DMS-30LCD Simplified Schematic

All 5V-powered DMS meters can be used to measure either single-ended or differential inputs. 9V-powered meters can only measure signals whose potentials are at least 1.5V above pin 3 (-BATTERY) and at least 1.5V below pin 1 (+BATTERY). A 9V meter can not be used to measure the 1.9V differential signal referred to in the previous paragraph (0.9 - (-1.0) = 1.9V) since the pin with -1Vdc applied (pin 12, (-) INPUT LO) is more negative than pin 3.

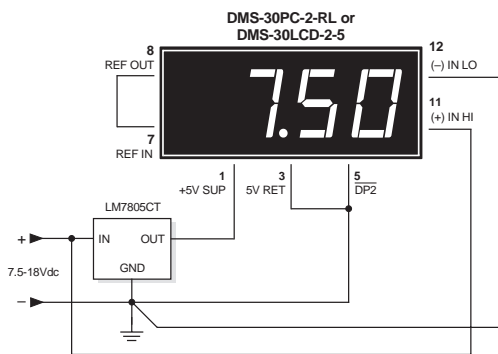

Figure 2. Three Terminal Regulator in Battery Monitor Circuit

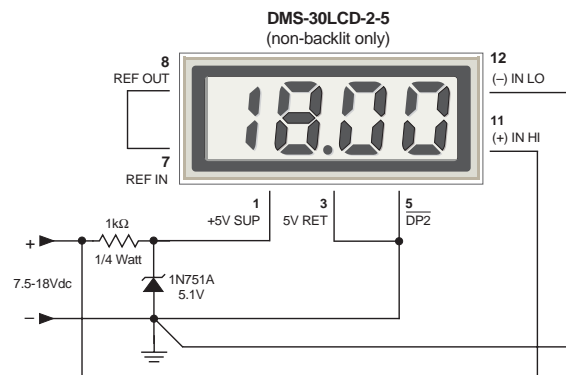

Figure 3. Zener Diode Regulator in Battery Monitor Circuit

9V-powered meters must never be wired in any configuration that has pin 11 or 12 tied directly to, or at the same potential as, pin 3. Doing so will drive the meter into an overrange condition (display flashes on and off or all digits are blank except for the left-most "1"). This condition is the number one cause of problems with 9V-powered LCD meters. How to solve it — or better still, avoid it — is covered next.

### 5V Regulators

In the real world of DPM's, there are many applications that are battery powered and also have their input referenced to, or even below, the negative battery terminal. In these applications, 5V-powered DMS meters must be used in order to avoid the above conditions. To accomplish this, the 9V battery must first be converted to a fairly clean, well regulated 5V. The two primary methods of accomplishing this are through the use of a three-terminal IC regulator or by using a zener diode in conjunction with a series limiting resistor. Figures 2 and 3 illustrate the two approaches.

The total power dissipation of all three components (LM7805, zener diode and series resistor) must be limited in order to prevent device overheating. The DMS-EB data sheet describes limitations to observe when using the LM7805. As a rule, non-backlit LCD meters can use the LM7805 with battery inputs up to 24Vdc.

### Power Supply Considerations

The subject of power sources for DATEL's DMS Series digital panel voltmeters may, at first, appear to be a simple topic that could be covered in two short paragraphs. The first would discuss 5V-powered meters and the second, 9V-powered meters. In most applications, the choice is straightforward. Usually all that is available is either a +5V power source, normally derived from the ac line, or a battery in the 6-12V range. In the former case, when all you have is 5V, you should obviously strive to use a 5V-powered meter (either LED or LCD).

It is economically unwise, although one could do so, to use some type of DC/DC conversion and generate 9V solely for the sake of using a 9V-powered meter. Conversely, there are times when it is necessary to use 5V-powered models when the only available power source is the 6-12V battery mentioned earlier.

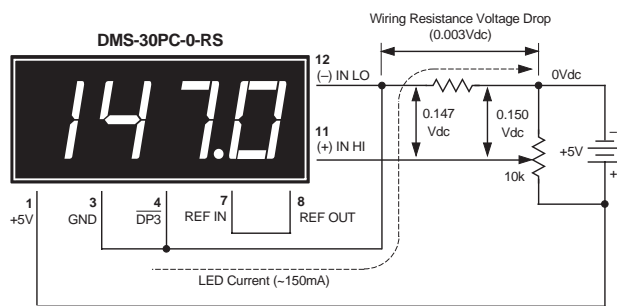

Figure 4. Single Ended Circuit with Ground-Loop Induced Errors.

All DATEL DMS meters require stable, well regulated, dc power supplies in order to achieve their full specified performance. All models have an internal, 1-2 microfarad, filter capacitor connected across pin 1 (+5V SUPPLY/+BATTERY) and pin 3 (5V RETURN/-BATTERY) to attenuate high-frequency noise. In most applications, this eliminates the need and additional expense of external decoupling capacitors. DC power sources with low-frequency (less than 1kHz) ripple and noise in excess of 50mV may induce instabilities in the meter's display and may require additional external power-supply filtering.

### Ground Loops

"Ground loops" are another topic that deserves discussion because they rear their ugly heads all too often, especially when precision 4½ digit meters are used. Ground loops can cause both inaccurate and unstable readings. The display can "jump" up or down ("hunting") by as many as 20 counts. It will almost never read all "0's" with zero Volts applied.

A harmful ground loop can occur any time current which powers the meter's display (current entering or leaving pin 3) becomes intermixed with signal current (the current flowing in or out of pin 12). This usually occurs only with single-ended input signals due to the fact that (-) INPUT LO, pin 12, is normally connected to pin 3 (GROUND).

Figure 4 illustrates a common ground-loop condition and the associated voltages that cause the display inaccuracies. The error voltages are generated because all wiring that has current flowing through it has a voltage drop (referred to as the "IR" drop) between one end of the wiring and the other end.

The solution to the problem is simple: avoid connecting pin 12, (-) INPUT LO, directly to pin 3 in single-ended applications. Use a separate wire or pc-board trace, originating at the power and/or signal ground point, to tie (-) INPUT LO to zero Volts. Figure 5 shows how to correctly wire a single-ended signal.

LCD display meters are not normally sensitive to ground-loop induced errors. The total current drain of these models is usually less than 1mA (compared to 100mA or higher for their LED counterparts). It never hurts, however, to always use the wiring precautions described above, especially if backlit displays, with their significantly higher supply currents, are used.

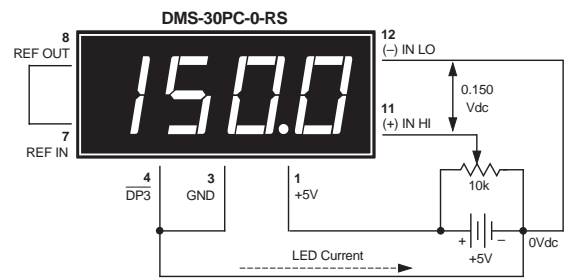

Figure 5. Correct Circuit Connections with No Ground-Loop Errors

