

# ANALOG COMMON and REFERENCE IN-OUT

## ANALOG COMMON

### Introduction

Perhaps the least understood I/O pin on all DMS Series DPM's is ANALOG COMMON (pin 10). The confusion surrounding this pin is not unjustified since **pin 10 should be left open, i.e., have no external connections, in the vast majority of normal meter applications.** Pin 10 should **not** be routinely connected to the power supply ground/common (pin 3), nor should it be connected to a system's signal (analog) ground/common.

Part of the confusion surrounding this pin arises from the fact that on some older DATEL DPM's, ANALOG COMMON must be connected to the system power supply common/return. This is not true for new DMS Series meters. In particular, never ground pin 10 on any DMS-20 Series meters or any of the 9V-powered meters in the DMS-30 or DMS-40 Series. Doing so will result in erroneous display readings.

### General Description

The following discussion applies to all DMS models except the DMS-40PC Series (4½ digit DPM with LED display), i.e., it applies to all DMS-20 and DMS-30 models and to the LCD models of the DMS-40 Series. The DMS-40PC will be covered separately.

ANALOG COMMON is a low-noise internal "reference" voltage used by the meters' analog-to-digital converter (A/D or ADC). For 9V-powered meters, pin 10 sits at a potential approximately 3 Volts below pin 1 (+BATTERY). For 5V-powered meters, ANALOG COMMON will be approximately 2 Volts above pin 3 (5V RETURN). If the 5V power supply were to suddenly drop down to 4V, however, ANALOG COMMON would then only measure 1 Volt above pin 3.

Pin 1 (+5V SUPPLY/+BATTERY), not pin 3, should always be used as the reference point if measuring ANALOG COMMON. This applies to both 5V and 9V-powered models of both LED and LCD meters — again, with the exception of the DMS-40PC.

On the DMS-40PC, pin 10 is also called ANALOG COMMON, and it is, again, a low noise "reference" for the meter's internal A/D converter. However, on these models, ANALOG COMMON is in fact internally tied to pin 3 (5V RETURN/-BATTERY), the power supply

common/ground. Even for these meters, ANALOG COMMON should not be externally connected to pin 3. Doing so will result in large LED currents flowing through pin 10 which can affect the A/D's reference point and cause highly unstable display readings.

### Using Analog Common

So why, you may ask, is ANALOG COMMON user accessible? A quick look at the application note on ohmmeters (part of which is reproduced in Figure 1 below) reveals that ANALOG COMMON is used to provide a voltage reference point which is independent of variations in the 9V power source. Additionally, it provides a bias point, well above -BATTERY, to which (+) INPUT HI (pin 11) and (-) INPUT LO (pin 12) are referenced. Recall that for 9V-powered meters, these two inputs must be kept at least 1.5V away from either supply rail.

In the simplified schematic of the DMS-30PC shown in Figure 2, we see that REFERENCE OUT (pin 8) essentially has ANALOG COMMON as its negative terminal. If a user chooses to generate an external adjustable reference input, its negative terminal must also be connected to ANALOG COMMON.

External reference circuits should be designed so that the current drawn from pin 10 is maintained between 50 and 200 microamps. Recommended resistor values for this function can be found in the appropriate individual product data sheets.

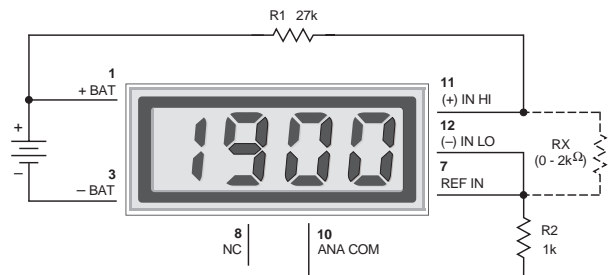

Figure 1. DMS-30LCD-0-9 in an Ohmmeter Application

# REFERENCE IN-OUT

## Introduction

Occasionally, DATEL's application engineers receive questions regarding the use and functionality of pins 7 (REFERENCE IN) and 8 (REFERENCE OUT) on DMS Series voltmeters. The most often asked question is simply, "what do I do with pins 7 and 8?". For the majority of applications, the answer is straightforward: for all DMS-20 and DMS-30 Series meters, tie pins 7 and 8 together; for all DMS-40 series meters, leave them open.

Leaving pin 7 (REFERENCE IN) open on DMS-20 and DMS-30 meters will cause the meters to go into a permanent overrange condition. Connecting pin 7 to pin 8 on DMS-40 meters will result in gross errors in the display reading since pin 8 is a decimal point location pin (DP4).

## General Description

The REFERENCE IN terminal determines the overall accuracy of the meter as the following equation illustrates:

$$\text{Display Reading} = (V_{IN} / V_{REF}) \times 1,000$$

This equation, which is effectively the transfer function of the meter, completely describes the meter's operation with a given input voltage. "Display Reading" is the number that will appear on the meter's LED/LCD readout.  $V_{IN}$  is the input voltage applied between (+) INPUT HI (pin 11) and (-) INPUT LO (pin 12).  $V_{REF}$  is the reference voltage applied to pin 7.

For all DMS-40 Series meters,  $V_{REF} = 1.000V$ . For DMS-20 and DMS-30 meters, with the exception of  $\pm 200mV$  input models,  $V_{REF}$  also equals  $1.000V_{dc}$ . For the  $\pm 200mV$  models,  $V_{REF} = 0.100V$ .

The following example illustrates how the above equation defines meter operation assuming that  $V_{IN} = 1.234V$  and  $V_{REF} = 1.000V$ .

$$\text{Display Reading} = (1.234 / 1.000) \times 1,000 = 1234$$

If DP1 is enabled, the reading will be 1.234. It is clear from this example that an adjustable  $V_{REF}$  could be used to vary the display reading for whatever purpose the user may have (compensation for component tolerances, transducer errors, etc.).

All DMS Series meters have a built-in reference-adjust (gain-adjust) potentiometer, located on the back of the unit, which provides a narrow range of calibration adjustment. Its main purpose is to "fine tune" the display reading to accuracies better than those guaranteed on the device data sheets. For DMS-20 and DMS-30 applications that require larger changes in  $V_{REF}$  (on the order of  $\pm 2\%$  to  $\pm 10\%$ ), consult the individual product data sheets.

## Ratiometric Operation

Ratiometric operation is normally used to compensate for an input signal that continuously varies for one reason or another (unregulated power supply, temperature fluctuations, etc.). An external REFERENCE IN signal is generated that varies proportionately with the changes in the input signal. Ratiometric operation, while not a common application, can be easily implemented with either DMS-20 or DMS-30 Series meters.

When using these meters in a ratiometric configuration, ANALOG COMMON (pin 10) **must be used** as the external reference's low side. If the external reference uses the +5V RETURN (pin 3) as its low side, ANALOG COMMON can be grounded and the external reference simply tied to pin 7. This applies only to 5V-powered meters. Please note that only positive references can be used, i.e., pin 7 must always be more positive than pin 10.

Some applications may require a DC/DC converter to provide isolation between the +5V powering the meter and the supply powering the input-signal electronics. Also note that ratiometric configurations, as well as external reference circuits, must **not** have pin 7 connected to pin 8.

The DMS-40PC and DMS-40LCD (4½ digit meters) have more complex internal reference circuitry, and though external gain adjustment circuits are possible, they also are more complicated. DATEL's application engineers will be more than happy to provide you with detailed information regarding the REFERENCE IN/OUT function on any DMS-40 meter

Once again, if your application requires ratiometric operation and you are using 9V-powered meters or any DMS-40 meter, we will provide you whatever assistance you may require.

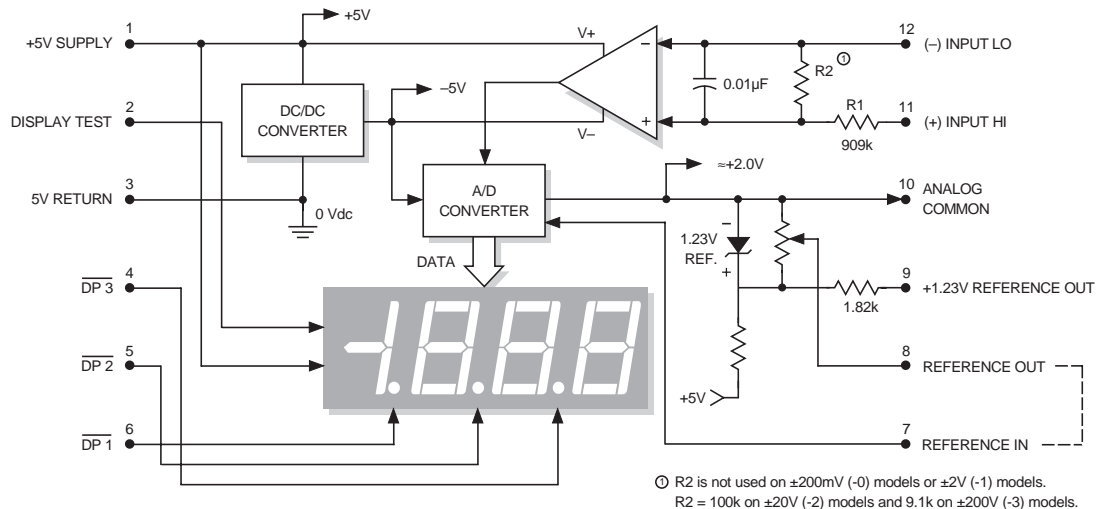

Figure 2. DMS-30PC Simplified Schematic