

# Direct Current Ammeters

## Introduction

There is a trend to replace older, analog-style readouts with modern digital displays. As one might expect, the conversion is not always a trivial task. This is especially true when the conversion involves older, moving-vane ("pointer" style) analog ammeters. The typical analog ammeter has only two wires to contend with, and the required shunt resistor is sometimes built-in to the meter itself. By comparison, its digital replacement may have as many as five or six input terminals. The project gets even more complicated when you include the required external current shunt. Hopefully, after reading this application note, you will have the necessary information to avoid the most common pitfalls associated with digital ammeter installations.

## Ammeter Theory

A digital ammeter is basically a very sensitive voltmeter with a typical input range of  $\pm 200\text{mV}$  (a DMS-30PC-0-RS for example). In order to convert the current to a voltage, the current must first pass through a device called a current shunt. A current shunt is a low-value resistor, usually one Ohm or less, that bypasses (or "shunts") the majority of the current flow around the meter.

Most current shunts have two pairs of terminals: one physically large pair to carry the load current and another smaller pair to carry the low-level signal voltage to the meter's input terminals (pins 11 and 12). The low-level signal connections do not require heavy-gauge wire. 22-26 AWG wire is sufficient since the current flow into the meter's input is extremely small. However, the load wires must be carefully chosen so as not to cause excessive heating and/or voltage drops. In most applications, the load wires also have to meet strict, electrical-code requirements. Questions on this type of installation must be referred to qualified personnel only.

## Basic Ammeter Example

The circuit shown in Figure 1 illustrates a typical digital ammeter consisting of a +5Vdc power supply, a  $0.1\Omega$  current shunt, and a  $\pm 200\text{mV}$ -input DMS-30PC. The application is to measure the current supplied to a heater element which consumes one Ampere in normal operation. This configuration poses no common mode voltage problems — more on this topic later in this application note — because the shunt is located in the power supply's ground terminal.

The easiest-to-use shunts have an output that is directly proportional to the current being measured, i.e., the shunt develops  $100\text{mV}$  with  $100$  Amperes through it. This type of shunt requires no additional scaling or amplification. A  $3\frac{1}{2}$  digit meter with a  $200\text{mV}$  input range will display "100.0", while a similar  $2\text{V}$ -input meter, used with the same shunt, will display "100".

In Figure 1, the  $0.1\Omega$  shunt, with  $1.0$  Amperes through it, will develop  $0.100\text{Vdc}$  or  $100\text{mV}$  across it. The voltage developed across a shunt is calculated using Ohm's law as follows: the shunt voltage is equal to the current through the shunt (in Amperes) multiplied by the shunt's resistance (in Ohms) or  $V(\text{shunt}) = I(\text{shunt}) \times R(\text{shunt})$ .

## Practical Ammeter Examples

The circuit shown in Figure 1, unfortunately, does not depict the typical real-world ammeter connection scheme which has the current shunt located in the high side (positive terminal) of the system power supply. In Figure 1, the voltage across the shunt is only  $0.1\text{Vdc}$  above pin 3 (5V RETURN). This is well below the  $\pm 2\text{V}$  common mode voltage limitation of the meter. Recall that all voltages at the meter's input terminals are measured with respect to pin 3.

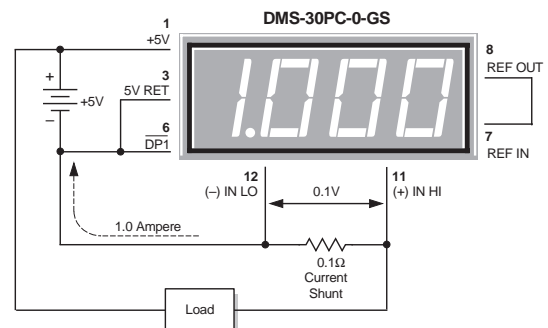

Figure 1. Basic Ammeter Circuit (Shunt in low side)

Figure 2 differs from Figure 1 in one very important respect: the current shunt is located in the high side of the system power supply. As previously stated, this is the most popular — and the most troublesome — ammeter configuration in use. This type of hookup requires the use of a DC/DC converter to provide the necessary isolation between the meter's 5V power source and the system power supply. If the DC/DC converter is not used, the meter's inputs (–)INPUT LO and (+)INPUT HI) will be at, or very close to, +5V. This condition violates the common-mode voltage limit of  $\pm 2V$  and will overrange the meter.

### 12V-Powered Ammeters

As a general rule, all ammeters using high-side current shunts must use an isolating DC/DC converter. Ignoring this rule could result in serious damage to the meter, particularly if power system voltages greater than +6Vdc are used. Systems that use two meters, one for Amperes, the other for Volts, even if a DC/DC converter is used, can still be troublesome.

Figure 3 shows the correct connections for a typical two-meter application. The DC/DC converter is required because the 0.1 $\Omega$  current shunt is connected to the positive terminal of the 12V battery. If the shunt was connected in the negative side of the battery (low side), both meters could be powered from the LM7805CT regulator. The DC/DC converter would not be required. Please note that while the LM7805CT can power as many as 10 DMS-30PC-X-RL (low-power red LED) meters, it can only supply power to one standard-intensity DMS-30PC meter.

### DMS-EB-DC/DC Application Board

DATEL's DMS-EB-DC/DC application board, with its built-in DC/DC converter, greatly simplifies the connections required for ammeters with high-side current shunts. As shipped, the DMS-EB-DC/DC board will provide an isolated 5V output from a 4.5-5.5V input. If only 12V power is available, the user can easily install an LM7805CT voltage regulator. See the DMS-EB-DC/DC data sheet for more information.

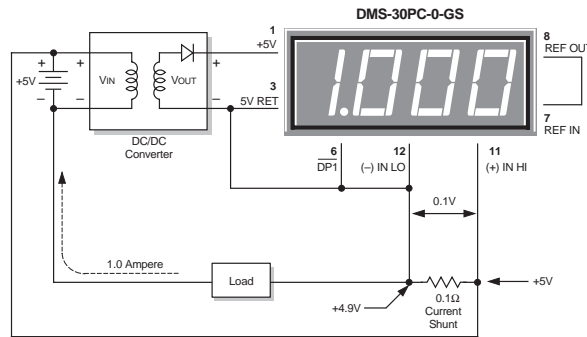

Figure 2. Basic Ammeter Circuit (Shunt in high side)

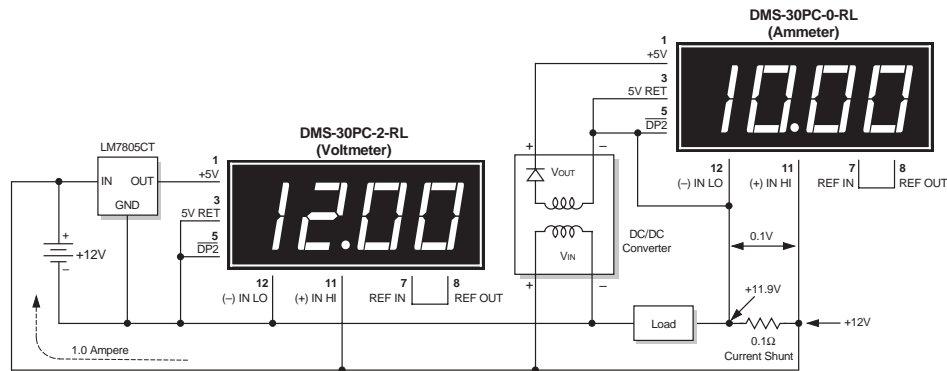

Figure 3. Measuring Amperes and Volts



DATEL, Inc. 11 Cabot Boulevard, Mansfield, MA 02048-1151  
 Tel: (508) 339-3000 (800) 233-2765 Fax: (508) 339-6356  
 Internet: www.datel.com Email: sales@datel.com  
 Data sheet fax back: (508) 261-2857

DATEL (UK) LTD. Tadley, England Tel: (01256)-880444  
 DATEL S.A.R.L. Montigny Le Bretonneux, France Tel: 01-34-60-01-01  
 DATEL GmbH München, Germany Tel: 89-544334-0  
 DATEL KK Tokyo, Japan Tel: 3-3779-1031, Osaka Tel: 6-354-2025