

Multi-Purpose Application Board for DMS-20PC/LCD Meters

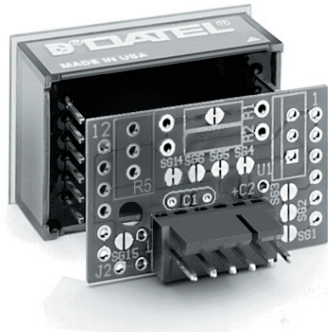

FEATURES

- Gain (span) adjustment
- Input divider network for attenuating voltages up to 250Vdc
- Operate meter and board from +5V supply or 9/12V battery
- On-board solder gaps for decimal point placement
- On-board I/O connector for easy power and signal input

The DMS-EB2 Application Board was designed for quick and easy application/evaluation of DATEL's subminiature DMS-20PC/LCD Series, 3½ Digit, LED/LCD Display, Digital Panel Voltmeters. The DMS-EB2's versatility, low cost and direct DMS-20PC/LCD plug-in compatibility makes interfacing a breeze. The DMS-EB2 covers many common panel-meter applications while providing easy signal and power I/O terminations (via a standard MOLEX connector) and plug-in versatility when changing from one application to another.

The DMS-EB2 has provisions for such common applications as input dividers for high input voltages, gain (span) adjustment, 9/12Vdc battery operation, and decimal point placement. The board permits direct signal I/O wiring via the interface connector or soldering directly to the board. The DMS-EB2 is fully compatible with all four versions of the DMS-20PC/LCD ($\pm 200\text{mV}$, $\pm 2\text{V}$, $\pm 20\text{V}$, $\pm 200\text{V}$) making it interchangeable from meter to meter and application to application. Solder gaps are conveniently placed on the board and may be quickly bridged or cut as required.

This low-cost addition to DATEL's expanding line of subminiature meters demonstrates our continuing commitment to offer the most versatile, easy-to-use panel-meter products.

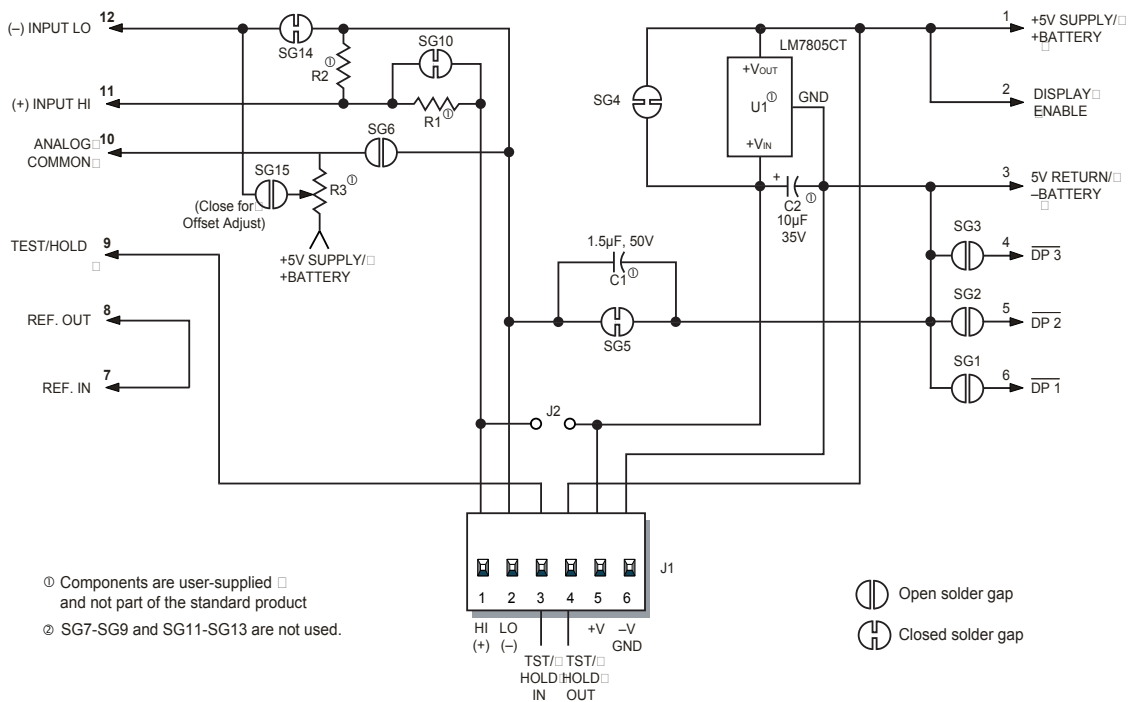
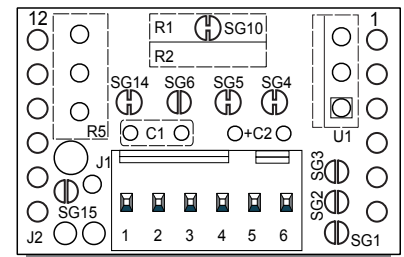

Figure 1. DMS-EB2 Schematic Diagram

Functional Specifications (T_A = 25°C)

Input Supply Range

See applicable meter's data sheet

Input Supply Range U1 (LM7805CT) Installed:

DMS-20PC-XXS	+7.5 to +12.6V
DMS-20PC-XXL	+7.5 to +32.0V
DMS-20LCD-X-5	+7.5 to +32.0V
DMS-20LCD-X-5B	+7.5 to +12.6V

Operating and Storage Temperature

See applicable meter's data sheet

Humidity 0 to 95%, non-condensing

Dimensions 1.25" (31.8mm)L x 0.75" (19.1mm)H

J1 Connector & Wire Information

Terminal Type	DATEL P/N 39-2099090
Crimp Tool	DATEL P/N 39-2099000
Wire Size	22 to 26 AWG
Insulation Diameter	0.062" (1.57mm) max.
Stripping Length	0.100" to 0.125" (2.54 to 3.17mm)

Ordering Information

DMS-EB2	Application board with mating connector and terminals
DMS-BZL3	DMS-20 bezel assembly
DMS-BZL4	DMS-20 bezel assembly with sealing gasket
39-0304000	LM7805CT (U1), +5V-output, three-terminal regulator
39-2359625	6-position pc-board socket

TECHNICAL NOTES

- LCD Backlighting:** To backlight a DMS-20LCD meter, connect J1, pin 3 (TEST/HOLD IN) to J1, pin 6 (GND). This allows for external control, via a switch, of the backlight feature. The switch should be rated for low voltage operation at 35mA.
- 9V LCD Meters:** DMS-20LCD-X-9 meters cannot be used in a single-ended configuration, i.e., with (-) IN LO tied to GND. On these models, both (-) IN LO and (+) IN HI have to be a minimum of 1.5V above and 1.5V below J1 pins 6 and 5, respectively. To operate from a 9V or 12V battery with (-) IN LO tied to GND, use a 5V-powered meter (DMS-20LCD-X-5), install U1 (LM7805CT) and open SG4.
- Input Resistor Dividers:** Always use 1%, or better, metal-film resistors for R1 and R2, and also make sure their power and voltage ratings are adequate for the given application.
- Using U1 (LM7805CT):** The input power range specified in the Battery Operation section is rated conservatively assuming a 100mA LED meter or a 35mA backlit LCD meter. If a non-backlit LCD model or the low-power LED model is used, the input voltage range can be extended up to 32Vdc.

A 10 μ F/35V tantalum capacitor (C2 on schematic) should be installed with the polarized end next to the + symbol on the DMS-EB2. This is especially important if the power source is located far from U1.

- Soldering:** DATEL recommends the use of "no-clean" solders when making modifications to the DMS-EB2.

APPLICATIONS

As shipped, the DMS-EB2 is configured for single-ended operation. This configuration is preferred for simple voltage measurements and will generally cover most standard applications. Figure 1 indicates which solder gaps are shipped closed from the factory.

Simply solder the board onto the meter (pin 1 to pin 1), connect the power supply to J1, pin 5 (+V) and the power return to J1, pin 6 (GROUND).

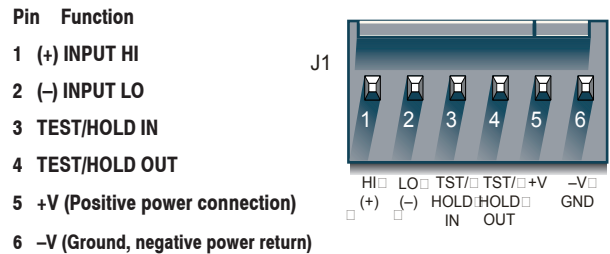

Figure 2. J1 Connector Pinout

- Decimal Point Placement:** DATEL ships the DMS-EB2 with all decimal point solder gaps (SG1, SG2 and SG3) open. To enable a specific decimal point, close its respective solder gap with solder. When re-assigning decimal places for subsequent applications, remember to unsolder previously closed solder gaps.

Close SG1 for 1.999 (DP1)
Close SG2 for 19.99 (DP2)
Close SG3 for 199.9 (DP3)

- Display Test** (Not Available on LCD Models): Tie pin 4 (TEST/HOLD OUT) to pin 3 (TEST/HOLD IN) to test the display of the DMS-20PC. Do not leave the meter in the test mode for more than 10 seconds. On LED meters with the HOLD option, tying pins 3 and 4 together freezes the display reading.
- Battery Operation:** Open SG4 and install U1 (LM7805CT) with its metal tab facing to the left as shown in Figure 3. Allowable input power ranges (J1, pins 5 and 6) are as follows:

DMS-20PC-XXS +7.5 to +12.6Vdc
DMS-20PC-XXL +7.5 to +32Vdc

C2 (10 μ F/35V) can be added to reduce noise. Observe correct polarity. Refer to Technical Note 4 for more information.

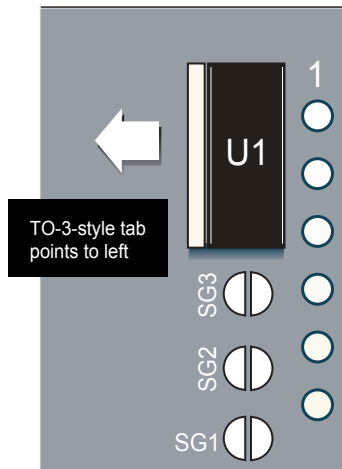

Figure 3. Installing U1

- 4. Calibration Adjustment:** The DMS-EB2 has provisions for adjusting the calibration of the DMS-20 meter. Calibration adjustment is useful when an input divider (using R1 and R2) is necessary to scale the input voltage. The calibration potentiometer allows "tweaking" of the display reading.

Using the calibration potentiometer

Adjust the calibration pot on the back of the meter as desired. The adjustment range is only 3/4 of a turn. Do not force the pot past its end stops.

- 5. Differential Input Signals** (Signal Referenced to Power Source): Open SG5. Apply the input signal to pin 1, (+) IN HI, and pin 2, (-) IN LO, of J1.

NOTE: Common mode voltage must not exceed ± 2 Vdc.

- 6. Measuring Input Voltages Greater than 1.999Vdc** (Use DMS-20PC/LCD-1 Only):

CAUTION: Do not exceed 250Vdc input signal.

1. Open SG10. For applications in which input voltages exceed ± 100 Vdc, also cut the 2 adjoining traces.
2. Calculate values for R1 and R2 as follows:

$$R2 = (FSI \times R1) / (|V_{IN}| - FSI)$$

Where:

FSI = The attenuated voltage, between the meter's (-) IN LO and (+) IN HI pins, needed to achieve the desired display readings

V_{IN} = Input voltage at J1 (between pins 1 and 2)

A typical value for R1 is 1M Ω . The sum of R1 + R2 should be between 50k Ω and 10M Ω .

3. Enable DP3 by soldering SG3.
4. Calibrate the meter using a known voltage source. Adjust the internal gain potentiometer to compensate for variations in R1 and R2.

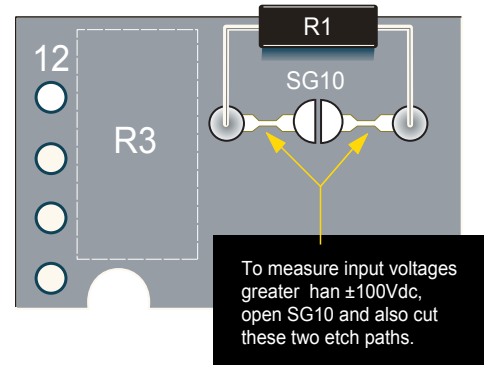

Figure 4. Installing R1

Example

V_{IN} is 199.9Vdc, and the display reading must be "199.9".

1. Assume R1 = 1.0M Ω .
2. $R2 = (FSI \times R1) / (|V_{IN}| - FSI)$
 $R2 = (1.999 \times 1,000,000) / (199.9 - 1.999)$
 $R2 = 10101.01\Omega$ or 10k Ω

- 7. Current Measurements** (Use 200mV Model, DMS-20PC/LCD-0): The following instructions are for measuring current derived from the DMS-20PC/LCD's power source. When measuring current that is floating with respect to J1, pin 6 (GROUND), leave SG5 closed.

CAUTION: Do not exceed 1 Ampere input current.

1. Install R2 ($R2 = FSR / (I_{MAX} \times 10000)$) where FSR is the desired reading (0-1999) and I_{MAX} is between 0-1 Ampere.
2. Open SG5.
3. Apply input signal (current) to (+) IN HI and (-) IN LO.
4. Adjust internal gain pot for desired full scale readings.
5. Enable decimal points using either SG1, SG2 or SG3.

Example

A 1.0 Ampere input must read "1.000" on the display.

$$R2 = 1000 / (1 \times 10000)$$

$$R2 = 0.1 \text{ Ohm}$$

Enable DP1 via SG1 for reading of 1.000

- 8. Displaying DMS-20PC/LCD's Power Source** (Use DMS-20PC/LCD-2, 5V-Powered Models Only):

1. If the power source is higher than 5Vdc, be sure to install U1 and cut SG4. See Battery Operation section and Technical Note 4.
2. Solder a short piece of jumper wire across the two holes labeled J2.
3. Close SG2 to enable DP2.