



FEATURES

- Super-bright LED displays are readable in direct sunlight!
- Autodim circuitry automatically adjusts display brightness
- Includes external brightness adjustment
- Large (0.56"/14.2mm) easy-to-read red LED display
- High reliability alternative to LCD displays
- Ideal for automotive, industrial, and marine applications
- Encapsulated package mounts in panels or pc-boards
- Miniature housing: 2.17" x 0.92" x 0.56" (55mm x 23mm x 14mm)
- 4 differential input ranges provide ± 1 count accuracy
- Single +5V supply; Less than 1-Watt power consumption
- 0 to +60°C operating temperature range

C&D Technologies' new DMS-30DR Series are the first digital panel meters to offer LED displays that are readable in direct sunlight—no special filters or shading devices are required. Their Autodim circuit automatically adjusts the display's brightness to suit viewing environments ranging from total darkness to full, brilliant sunlight. A user-accessible brightness adjustment pin enables custom intensity settings or display matching in multiple display applications. Washed out, hard-to-read digital readouts are a thing of the past!

Until now, users whose instrumentation required daylight visibility had to settle for less reliable LCD display technology. However, in order to remain legible in low ambient light, LCDs require complex, power-hungry backlighting circuitry. And, these displays typically suffer from very narrow viewing angles. In contrast, DMS-30DR Series LED-based displays' power consumption drops as ambient light decreases, and their viewing angle extends to nearly 180 degrees vertically and horizontally.

All models operate from a single +5V supply, and draw as little as 7mA when operated in total darkness—that's less than 1/10 Watt. At maximum brightness power consumption is typically less than 200mA (1 Watt). DMS-30DR voltmeters are available in four differential input voltage ranges: ± 200 mV, ± 2 V, ± 20 V and ± 200 V. Input impedance is 1,000 megohms for the ± 200 mV and ± 2 V inputs and 1 megohm for the ± 20 V and ± 200 V inputs. CMRR for all devices is 86dB, and inputs are overvoltage protected to ± 250 V. Each meter incorporates a precision, ultra-stable voltage reference and is factory calibrated prior to encapsulation.

The small size (2.17" x 0.92" x 0.56") of DMS-30DR meters is achieved by integrating their display, Autodim display drivers, light sensor, reference circuit, and A/D converter into in a rugged epoxy-encapsulated assembly. The device's 12-pin, component-like, DIP package is both vibration and moisture proof, making them ideal for harsh environments. Each package incorporates a built-in color filter and bezel, and is easily mounted in either panels or pc boards.

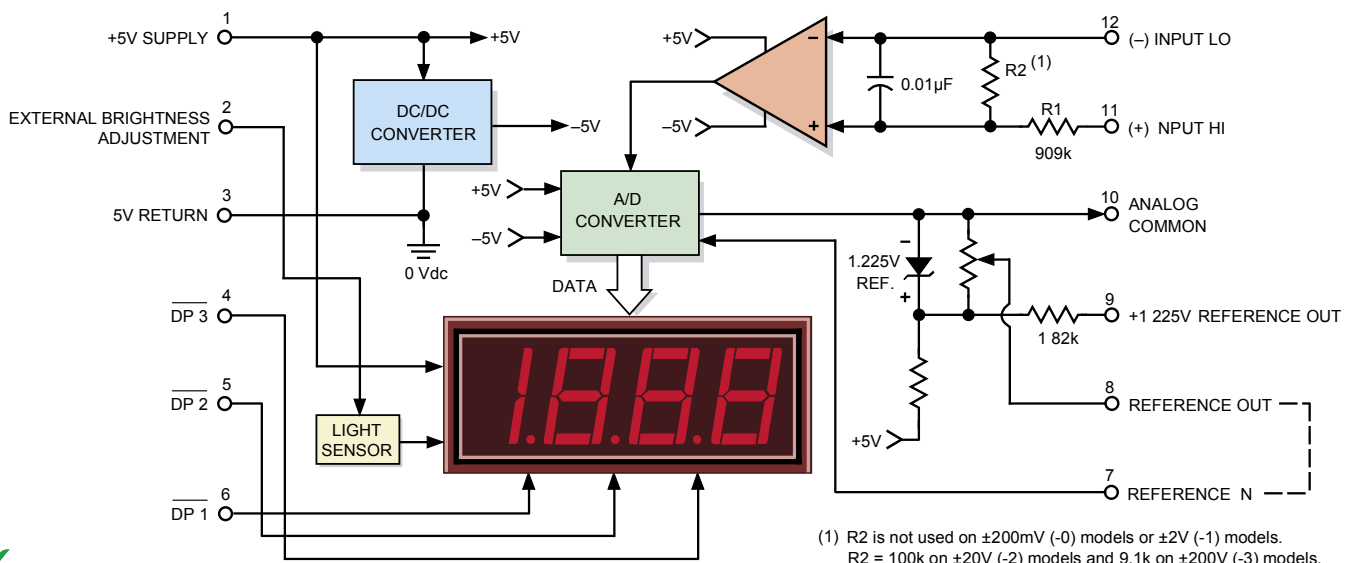

(1) R2 is not used on ± 200 mV (-0) models or ± 2 V (-1) models.
R2 = 100k on ± 20 V (-2) models and 9.1k on ± 200 V (-3) models.

Figure 1. DMS-30DR Simplified Schematic



Performance/Functional Specifications

Typical at T_A = +25°C and supply voltage = +5V using the single-ended input circuit, unless otherwise noted.

Analog Inputs	Min.	Typ.	Max.	Units
Full Scale Input Range:				
DMS-30DR-0	–	±200	–	mV
DMS-30DR-1	–	±2	–	Volts
DMS-30DR-2	–	±20	–	Volts
DMS-30DR-3	–	±200	–	Volts
Input Impedance:	–			
DMS-30DR-0, -1	100	1000	–	MΩ
DMS-30DR-2, -3	0.9	1	–	MΩ
Overvoltage Protection ①	–	–	±250	Volts
Common Mode Voltage Range	–	–	±2	Volts
CMRR (dc to 60Hz)	–	86	–	dB
Control Inputs ②				
Decimal Point Placement (Pins 4-6)	Tie to pin 3 to activate			
Ext. Bright (Pin 2)	See Technical Note 1			
Performance				
Sampling Rate	2.5 reading per second			
Accuracy (3 minute warm-up):				
DMS-30PC-0 (V _{in} = +0.19V)	–	±1	±3	Counts
DMS-30PC-1 (V _{in} = +1.9V)	–	±1	±3	Counts
DMS-30PC-2 (V _{in} = +19V)	–	±2	±3	Counts
DMS-30PC-3 (V _{in} = +190V)	–	±2	±3	Counts
Zero Reading (V _{in} = 0 Volts)	"–001"	"000"	"001"	
Temperature Drift (0 = +60°C)	–	±0.2	±0.4	Cnts/°C
+1.225V Reference Output (Pin 9)②	+1.215	+1.225	+1.235	Volts
Power Supply Requirements				
Supply Voltage	+4.75	+5.00	+5.25	Volts
Supply Current:				
Full Sunlight	–	+150	+250	mA
Total Darkness	–	3	5	mA
Display				
Display Type and Size	3½ digit, 0.56"/14.2mm high LED			
Polarity Indication	Autopolarity ("–" for negative V _{in})			
Overrange Indication	"–1 ___" for negative inputs "1 ___" for positive inputs			
Physical/Environmental				
Operating Temperature	0	–	+60	°C
Storage Temperature	–40	–	+75	°C
Humidity (non-condensing)	0	–	95	%
Case Material	Polycarbonate			
Weight	0.75 ounces (21 grams)			

① Applies for transient or continuous overvoltages applied to (+) INPUT HI (pin 11) with (–) INPUT LO (pin 12) properly connected. Pin 12 is not overvoltage protected (see Figure 1). Voltages applied to pin 12 should not exceed the supply voltage.

② See Technical Notes.

Ordering Information

DMS-30DR-1-R-C

PATENT PENDING

Input Range:

0 = ±200mV
1 = ±2V
2 = ±20V
3 = ±200V

RoHS Compliant

LED Color:
R = Red



Accessories:

DMS-EB-C Multi-purpose (gain/offset, 4-20mA, etc.)
DMS-EB-RMS-C For true rms measurements of ac voltages
DMS-PS1-CM-C +5V/1.0A AC/DC power supply module
DMS-30-CP Panel cutout punch

A panel-mount DMS-BZL2-C is supplied with each unit.

Buy Online: www.DataMeters.com

TECHNICAL NOTES

1. External Brightness Adjustment (Pin 2): Pin 2 is internally connected to the high impedance input of an operational amplifier that amplifies the output of the DMS-30DR's ambient light sensor (ALS) circuit. The output of this amplifier varies the voltage that drives the DMS-30DR's LED display. Leave pin 2 open for standard auto-dimming operation; in this mode, the ALS circuit will automatically adjust the DMS-30DR's LED brightness to compensate for changes in ambient lighting. As the ambient light striking the ALS increases, the LED display's brightness will also increase; a decrease in ambient light will reduce the display's brightness.

The ALS circuit's output signal can be overdriven by applying an externally generated voltage directly to pin 2. External drivers will see approximately 600Kohms referenced to 5V RETURN. With pin 2 at +0.7Vdc or below, the DMS-30DR's LED display is off, and total current drain from a nominal +5V supply is approximately 1mA. The LED display's brightness will increase from minimum to maximum as the voltage applied to pin 2 is varied from +0.8V up to +2.5V, respectively. To enable continuous maximum display brightness, connect pin 2 directly to pin 1 (+5V SUPPLY); in this configuration the total current drain for the meter will be approximately 200mA.

2. Minimum-Intensity Adjustment Potentiometer: Users can adjust the DMS-30DR's minimum LED brightness to suit their requirements by adjusting the ¾-turn, rear-mounted intensity adjustment potentiometer. Please note, this potentiometer will have minimal impact on display brightness in high ambient light environments. See the Mechanical Specifications section for potentiometer locations.

The intensity adjustment potentiometer is factory preset to its mid-point position, producing a typical current drain of 7mA. At its minimum and maximum positions, current drain is typically 3mA and 13mA, respectively. As viewed from the rear of the meter, with the model number label facing up, turning the potentiometer clockwise increases the display's intensity.

3. +1.225V REFERENCE OUTPUT (Pin 9): This pin is the output of the meter's precision +1.225V internal reference IC. Pin 9 is referenced to ANALOG COMMON (pin 10), which in turn sits approximately +2V above pin 3. Pin 9 should be buffered if it's used to drive external loads since sourcing more than 15µA of current can affect both the

accuracy and temperature drift of the meter. A $\pm 1\%$ 1.82K limiting resistor is connected between the reference IC and pin 9.

- 4. ANALOG COMMON (Pin 10):** This pin is connected to an internal, low-noise, “relative” ground. Pin 10 also serves as the internal ground for the +1.225V reference IC. ANALOG COMMON is used in certain differential and “floating” measurements as described in the Applications section of this data sheet, and in DMS Application Note 3. For the vast majority of applications, pin 10 should not be connected to pin 3 (5V RETURN), or to your system’s analog ground.
- 5. REFERENCE OUTPUT (Pin 8) and INPUT (Pin 7):** Pin 8 is a precision reference actively trimmed at the factory. For normal operation, pin 8 must be tied to pin 7 to achieve all listed accuracy and drift specifications.
- 6. Decimal Point Placement:** The location of the decimal point is user selectable, and the decimal point control pins (DP1-DP3) are active low functions. Select the desired decimal point by tying the appropriate pin (pin 4, 5 or 6) to pin 3 (5V RETURN). Unused decimal point location pins should be left open. Hard wiring is preferable, however, you can use logic gates to exercise dynamic control over the location of the decimal point if the following drive conditions are met:

Applied “0” Voltage: +0.4V max
Drive Current*: 6mA max.

* The driving gates must be able to sink this much current (IOL) with a logic “0” output.

- 7. Gain-Adjust Potentiometer:** The gain-adjust potentiometer located on the rear of the meter has approximately ± 50 counts ($\pm 2.5\%$) of adjustment range with a near full-scale input. Since these meters essentially have no zero/offset errors, a gain adjustment is effectively an overall accuracy adjustment. Though they may be performed at any input level except zero, accuracy adjustments are most effective when performed with half-scale (or higher) positive input signals.

If a wider adjustment range is required, an external potentiometer circuit can be configured using the meter’s +1.225V reference output (pin 9). The circuit shown in Figure 9 provides $\pm 10\%$ range of adjustment.

- 8. Soldering Methods:** All models in the DMS-30DR Series easily withstand most common leaded or lead-free soldering operations, performed either manually or by wave soldering machines. However, users should evaluate the effects their particular soldering techniques may have on the meter’s plastic case and precision electrical performance. We highly recommend using low residue, no-clean solders.

9. Suggested Mating Connectors:

Panel mounted: Connector housing P/N 4320-01069-0
Terminal type: P/N 4400-01032-0
Crimping tool: P/N 39-2099000
Wire size: 22 to 26 AWG
Insulation diameter: 0.062” (1.57mm) maximum
Stripping length: 0.100 to 0.125” (2.54 to 3.17mm)
Board mounted: Socket: P/N 4320-01074-0

APPLICATIONS

DMS-30DR meters are highly versatile devices that can be used in hundreds of applications. The application circuits chosen for this section have historically received many inquiries. Every attempt has been made to ensure technical accuracy, and all of the following circuits have been prototyped and tested to ensure functionality. Please keep in mind, however, that real-world applications are seldom as straightforward as the approaches presented here. Most applications have many more components — and many more connections — than the illustrations show.

The simplified schematic shown in Figure 1 can be very useful when debugging a malfunctioning panel meter circuit, particularly if the user has some knowledge of operational amplifiers (op amps). The meter’s high-impedance input consists of an op amp powered from a $\pm 5Vdc$ power supply (the $-5V$ is internally generated). Knowing this, one can easily see why input signals applied to (–) INPUT LO and (+) INPUT HI have to be kept within the power supply rails of $\pm 5V$. Also note that only pin 11 has a current-limiting 909k Ω series resistor. High input voltages that have a common ground with pin 3 (5V RETURN) should only be applied to pin 11 ((+) INPUT HI) and never to pin 12. In these high-voltage cases, pin 12 should always be tied to pin 3 (5V RETURN).

One of the simplified schematic’s noteworthy features is that it shows internal voltage values. It also shows that pin 3 is the meter’s zero-volt reference point — regardless of the type of power or signal source used. This is an important point to keep in mind when a digital or analog multimeter is used to make system measurements. The multimeter’s negative lead (usually the black one) must be connected to pin 3 (5V RETURN).

- 1. Single-Ended Input Configurations:** True single-ended measurements can be made with any DMS-30DR meter. The circuit of Figure 2 avoids problems normally associated with ground-loop currents. Separate ground runs should be used for 5V RETURN (pin 3) and (–) INPUT LO (pin 12). This will ensure that large LED currents will not flow in the wiring that connects V_{IN} to (–) INPUT LO (pin 12). Ground-loop currents can cause unstable readings.

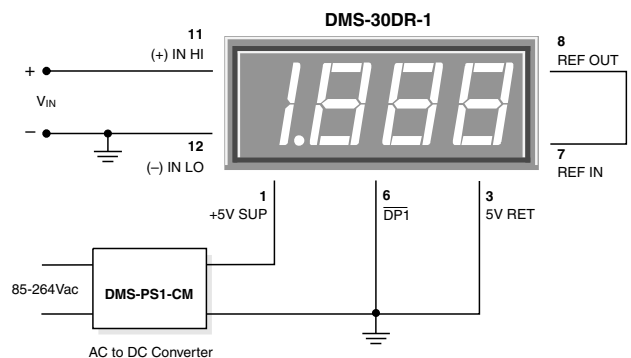

Figure 2. Single-Ended Input Configuration

APPLICATIONS

2. Differential Input Configurations: Differential measurements can be made with all DMS-30DR meters. Figure 3, though not a practical real-world application, uses a voltage divider to demonstrate the concept of a differential input signal. Be careful not to exceed the ±2V common mode voltage limitation for 5V-powered meters.

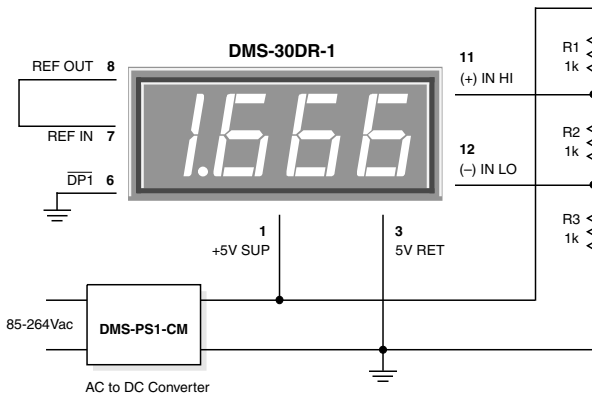

Figure 3. Differential Input Configuration

3. Engineering Scaling: For measuring voltages greater than the full scale input range of a given meter, the input signal must be attenuated. A simple voltage divider (similar to that shown in Figure 4) will scale the input to within the range of the selected meter. R1 and R2 should be precision, ±1%, metal-film resistors with absolute TCR's less than 50ppm/°C. See Ap Note 4 for more information on engineering scaling.

$$50k\Omega < R1 + R2 < 10M\Omega$$

$$\frac{R2}{R1 + R2} \times V_{IN} = \text{Reading}$$

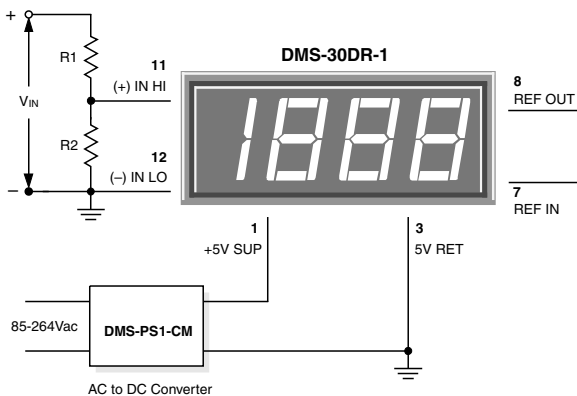

Figure 4. Input Attenuation Circuit

4. Floating Signal Source Measurements: Floating signals can be measured using the circuits shown in Figures 5 and 6. Connecting pin 10 (ANALOG COMMON) or pin 3 (5V RETURN) to (-) INPUT LO (pin 12) provides the reference point for the meter's input.

A "floating" input is a signal that has no galvanic connection to the meter's power supply. In the figures below, the 1.5V battery illustrates a true floating input.

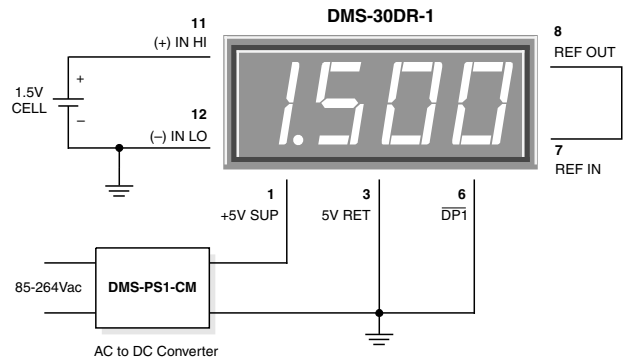

Figure 5. Floating Input Measurements

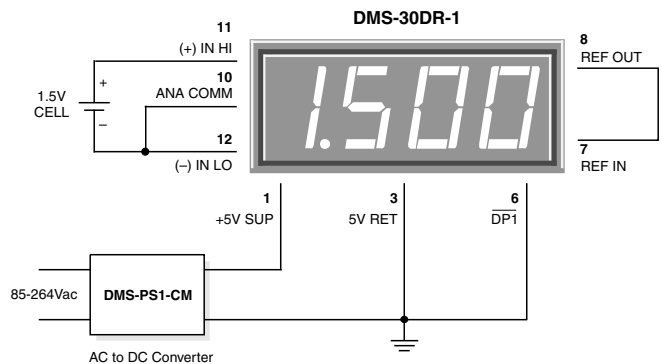

Figure 6. Floating Input Measurements (Alternate Configuration)

5. Process Control (4-to-20mA) Measurements: In many common process-control applications, a 4-to-20mA current loop is used to transmit information. Because DMS-30DR meters have such high input impedance, a simple shunt resistor across the meter's input can be used to convert the loop current to a voltage. See Figure 7. The value of the shunt resistor is a function of the scaling requirements of the particular application and can be calculated using the following equation:

$$R_{Shunt} = R1 = V_{Fsr} / I_{Fsr}$$

Where: V_{Fsr} = Full scale reading (in Volts)

I_{Fsr} = Relative full scale current (in Amps)

APPLICATIONS

Example: For a meter with a 2V full scale input (1.999 full scale reading) and a desired display reading of "1000" (with an input of 20mA), $V_{Fsr} = 1.000$ Volts

$$R_{Shunt} = 1.000V / (0.020 - 0.004)A$$

$$R_{Shunt} = 1.000V / 0.016A = 62.5 \text{ Ohms}$$

To calibrate the circuit of Figure 7, perform the following:

1. With 4mA applied, adjust the 50kΩ potentiometer (R2) to display a reading of "000" (assuming that is the desired reading).
2. With 20mA applied, adjust the gain-adjust potentiometer on the back of the meter to display a reading of "1000". For different full scale readings, alter the value of R_{Shunt} accordingly.

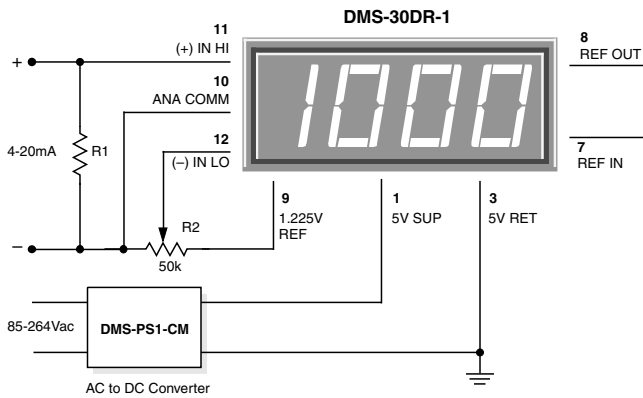

Figure 7. 4-to-20mA Current Loop Operation

6. Digital Ammeter: Digital ammeters are finding ever-increasing usage because analog-style ammeters (moving-vane types) now cost roughly the same as their digital counterparts. Additionally, analog ammeters are not nearly as rugged as modern digital panel voltmeters. Figure 9 illustrates a typical ammeter application. The circuit uses a $\pm 200mV$ input meter — the preferred range for most ammeters — to measure the voltage developed across a 0.1Ω current shunt. The circuit shown

represents a basic ammeter connection diagram. A detailed application note describing digital dc ammeters is available at www.cd4power.com.

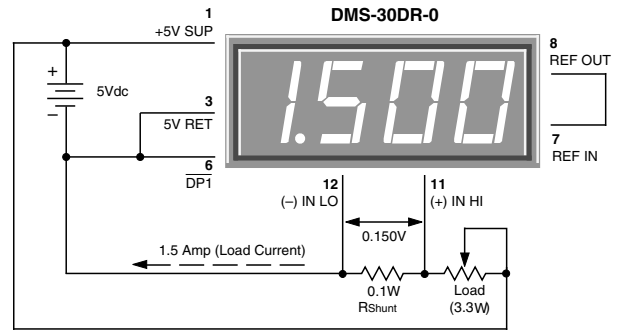

Figure 8. Basic DC Ammeter Circuit

7. External Gain Adjustment: Connect REFERENCE OUT (pin 8) to REFERENCE IN (pin 7) for normal, factory calibrated, operation. Use the +1.225V REFERENCE OUT (pin 9) for applications needing external gain adjustment. Figure 10 shows the wiring configuration for each model. Calibration is performed with a precise, near-full-scale, input voltage.

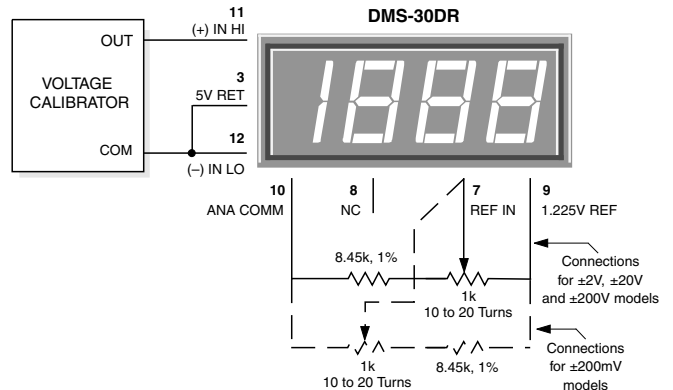
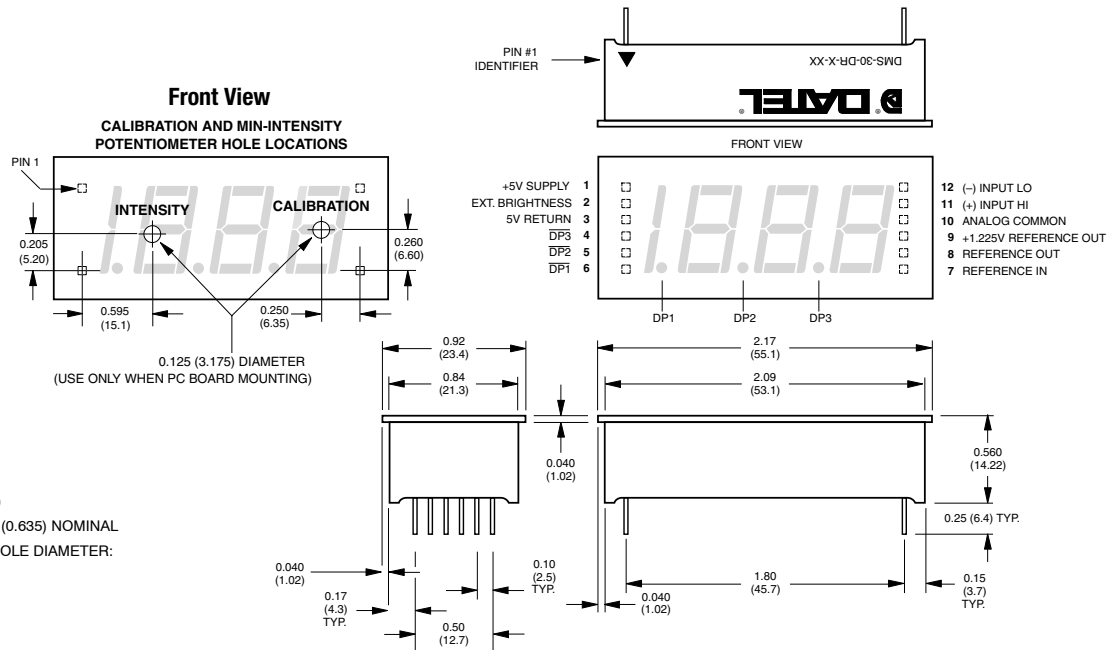
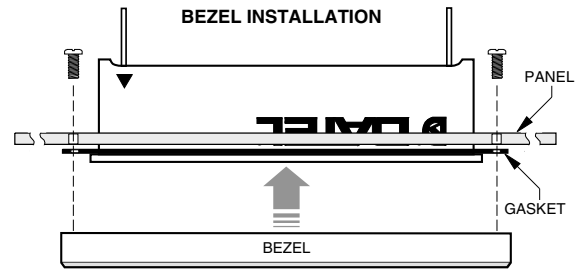
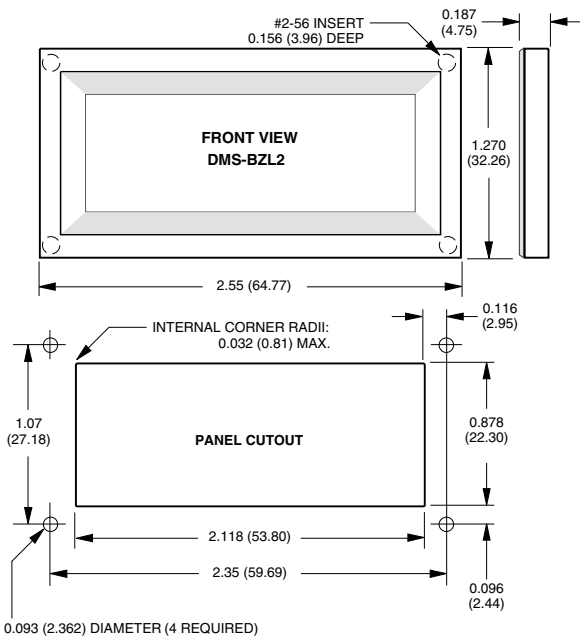

Figure 9. External Gain Adjustment

MECHANICAL SPECIFICATIONS



BEZEL INSTALLATION AND RECOMMENDED DRILL AND PANEL CUTOUT



Buy Online: www.DatelMeters.com

MeterCenter
 2046 West Peninsula Circle, Chandler, AZ 85248 U.S.A.
 Tel: (480) 659-8351 (800) 230-6008 Fax: (480) 659-8361
www.DatelMeters.com www.MeterCenter.com email: sales@MeterCenter.com
 DAMEL is ISO 9001 REGISTERED

DS-0268A 04/2007